



SEMESTER-4TH

BRANCH-ELECTRICAL ENGG.

**SUBJECT-ELECTRICAL MEASUREMENT
AND INSTRUMENTATION**

LECTURE NOTES

SUBMITTED BY :-PRATIMA BHOI

ELECTRICAL MEASUREMENTS & INSTRUMENTATION

CHAPTER- 1 MEASURING INSTRUMENTS

1.1 Define Accuracy , precision , Errors, Resolutions , Sensitivity and Tolerance

What is measurement:-

- Measurement is the process by which one can convert a physical parameters to meaningful numbers, by which it can be compared with other object or events.

Measuring Instruments :-

- A device for determining the values or magnitude of a quantity is known as measuring instruments.

Accuracy:-

- Accuracy is the degree of closeness with which an instrument reading approaches the true value of the quantity being measured.
- Accuracy indicates the degree of closeness of the measured value to a true value.
- This closeness must be high then accuracy is high.

EX-

<u>Am (Measured value)</u>	<u>At (True value)</u>
50 -----(0.3)-----	49.7
50 -----(0.2)-----	49.8
50 -----(0.1)-----	49.9 (more accuracy)

Precision:-

- Precision refers to the degree of closeness between the measured value when same input value measured number of times.
- Accurate instruments may be precise but precision will not confirm any accuracy.
- We prefer always accurate as well as precise instruments.

Ex- Suppose volume of a liquid is 20ml. A student measure the volume of the liquid by using cap and got the following result.

Sl no.	Measuring volume	Accuracy	Precision
1	20 ml,19.3ml,18.8ml, 18.6 ml	Good	Poor
2	16 ml,16.1ml,16.0ml, 16.2 ml	Poor	Good
3	20.1ml,20.0ml,20.2ml, 20.1 ml	Good	Good
4	18.6 ml,17.8ml,15.6ml, 16.2 ml	Poor	Poor

Errors :-

- The difference of magnitude between measured value (A_m) and true value (A_t) is called as error.

$$E = A_m - A_t$$

Where A_m = Measured value

A_t = True Value

- Error can be positive or negative.
- Classification of Error

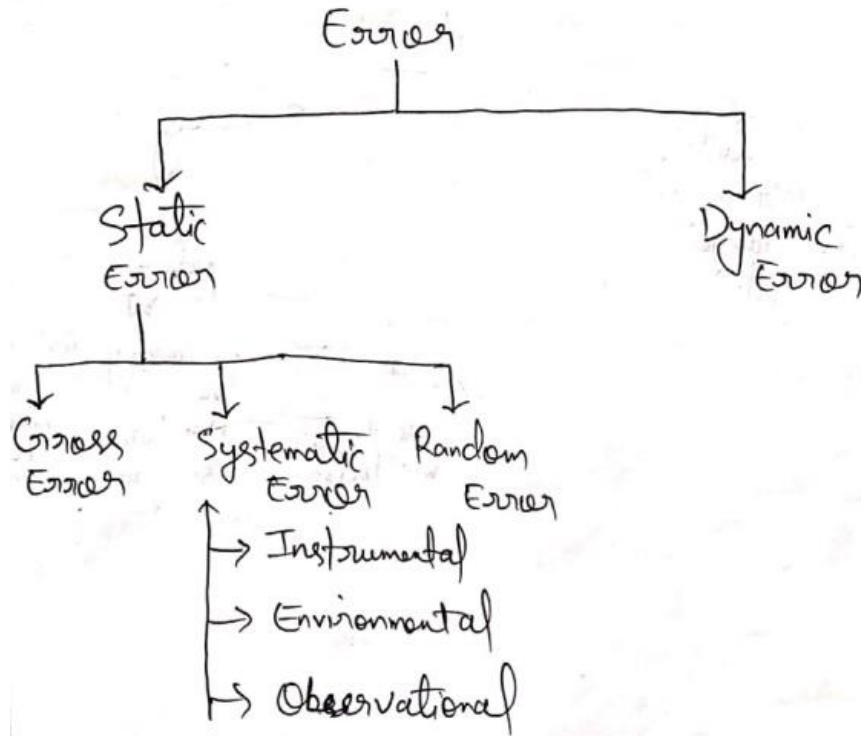

(a) Static Error:-

- The error which is independent on time is called as static error.

(b) Dynamic Error:-

- The error which is depends on time is called as dynamic error.

Types of static error:-

(a) Gross error:-

- These errors are completely due to human mistake that is doing loose connection, reading the values, taking values, memorizing and doing calculation.
- Gross errors are not common for all observers. These are variable errors.

(b) Systematic Error:-

(i) Instrumental Error:-

- These errors are due to misuse of an instrument (i.e choosing wrong range of an instruments), repeated loading and unloading, loading effect etc.

(ii) Environmental error:-

- These errors are due to temperature, pressure, humidity, dust etc.

(iii) Observational Error:-

- These errors are due to shadow of the pointer.

Systematic errors are constants errors and these are common for all observer.

(c) Random Error:-

- The error which cannot be predicted is called as random error.
- These errors can be eliminated by using mathematical analysis.

Resolutions:-

- It is the smallest change in measured value to which the instruments will response.
- Resolution define smallest measurable change in input.
- The smallest output that we can detect in the scale with certainty with clarity is called resolution.

$$R = \frac{\text{Full scale value}}{\text{Total no. of division}}$$

Q . A (0-200) volt, voltmeter with a division of 100 division and we can estimate $\frac{1}{10}$ th of the full scale division accurately. Find the resolution.

$$R = \frac{200}{100 \times 10} = 0.2$$

Sensitivity:-

- It is the ratio of change in output to the change in input

$$S = \frac{\Delta \text{ o/p}}{\Delta \text{ I/p}}$$

- Sensitivity of linear element is 1

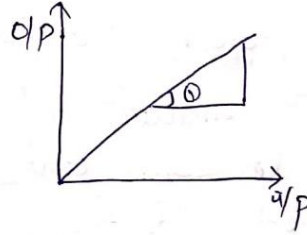

$$\frac{\Delta \text{ o/p}}{\Delta \text{ I/p}} = \text{slope} = \tan\theta$$

For $\theta = 45^\circ$
 $S = 1$

For every linear system a single sensitivity is defined and the angle of sensitivity is 45° ($S = 1$)

Tolerance:-

It is defined as the limit of variation in physical dimension.

1.2 Classification of Measuring instruments

Absolute instruments :-

- These instruments does not gives direct readings but gives in terms of instrumental constant.
- These type of instruments are rarely used in laboratories for standardization purpose.
 Ex- Tangent Galvanometer

Secondary instruments:-

- These instruments gives direct readings

(a) Indicating instruments

- These instruments are give the value of the quantity to be measured by the deflection of the pointer.
- It has scale and pointer mechanism.
 Ex-Ammeter, voltmeter, frequency meter, wattmeter, power factor meter etc.

Recording instruments:-

- These instruments are records the value to be measured over a graph paper by light weight pen.
- These are used to observed load variation continuously.

Ex- recording voltmeter, recording wattmeter

Integrating instruments:-

- These instruments are totalized the events over a specified range of time.
Ex- Energy meter, Ampere-hour meter

1.3 Explain Deflecting ,Controlling and Damping arrangements in indicating type of instruments.

There are three types of forces required for the satisfy operation of any indicating instruments. They are :-

1. Deflecting torque
2. Controlling torque
3. Damping torque

1. Deflecting torque

It is also called as operating force.

It is required for moving the pointer from its actual position.

The system producing the deflecting force is called as deflecting system on moving system.

So we can say the deflecting system of an instrument can convert the electric current or voltage into a mechanical force.

The torque produced by the deflecting force is called as deflecting torque (T_d).

2. Controlling torque

The force opposes to the deflecting force and increase with the defecting force of the moving system is called as controlling force.

The torque produced by the controlling force is called as controlling torque.

These torque oppose to the deflecting torque and increase with the deflection of the moving systems.

The pointer is brought to rest at a position where two opposite torque are equal ($T_d = T_c$) is known as final steady state position.

Thee controlling on balancing torque in indicating instrument is obtained by

- a. Spring control
- b. Gravity control

a. Spring control

In this method two spiral spring of phosphor bronze are wound in opposite direction on the spindle.

When the moving system is deflect, one of the spring is open and another close in opposite direction.

Here the controlling torque is provided by the spring control so that if the deflecting torque (T_d) is increased then the controlling torque (T_c) is also increased.

Here the controlling torque (T_c) \propto angle of deflection of pointer (θ)

That is $T_c \propto \theta$

$$T_c = K_s \theta$$

Where K_s = Spring constant

Deflecting torque (T_d) \propto current flowing through the instrument

That is $T_d \propto I$

$$T_d = K_d I$$

So at final steady state position $T_d = T_c$

$$K_d I = K_s \theta$$

$$\theta = \left(\frac{K_d}{K_s} \right) I$$

$$\theta \propto I$$

$$\theta = K I$$

So that the scale is uniform or linear

Advantages:-

Linear or uniform scale.

It can be mounted for both horizontally as well vertically/

Disadvantages:-

Complex construction than gravity control

Change in temperature affect the spring length and hence controlling torque.

Properties of spring control material

High conductivity.

High mechanical strength.

Non magnetic material

Gravity control :-

Here the deflecting position of control weight (w_2) can be converted into two components $w_2\sin\theta$, $w_2\cos\theta$.

Only $w_2\sin\theta$ will provide the controlling torque.

$$T_c \propto w_2\sin\theta.$$

$$T_c = K_c w_2\sin\theta.$$

$$T_d = K_d I$$

We know that deflecting torque $T_d \propto$ current (I) flowing through the instrument

So at final steady state position $T_d = T_c$

$$K_d I = K_c w_2\sin\theta.$$

$$I = \left(\frac{K_c w_2}{K_d}\right) \sin\theta.$$

$$I \propto \sin\theta$$

Therefore the gravity control instrument have non-uniform scale.

Advantages:-

No temperature effect.

Cheaper than spring control instrument.

Disadvantages:-

Non uniform scale.

Instrument has to kept in vertical position , because of gravity the pointer will make oscillations, while coming to steady state.

Comparison between Spring Control & Gravity Control

	Spring Control	Gravity Control
1	Variation in temperature causes an error in an instruments.	Independent of temperature.
2	It has uniform scale ($I \propto \theta$)	It has non-uniform scale ($I \propto \sin\theta$)
3	It can be used in any position (vertically , or horizontally)	It can be used only in vertical position.

4	It is costlier than gravity control.	It is cheaper than spring control.
---	--------------------------------------	------------------------------------

Damping Force

Damping force is the force by which the moving system comes to its equilibrium position rapidly and smoothly without any oscillation.

The torque produced by damping force is called damping torque (D_m).

- Damping torque is necessary to bring the pointer to rest position quickly. Otherwise due to the inertia of the moving system the pointer will oscillates about its final steady state position.
- The damping torque can be produced by using
 - a. Air friction Damping
 - b. Fluid friction Damping
 - c. Eddy current Damping

a. Air friction Damping

- It consists of a light aluminium piston which is attached to the moving system.
- When there is an oscillation on the pointer, then the piston will move upward and downward in the air chamber.
- When the piston moves downward, the pressurised air are compressed which opposes movements of the pointer and hence oscillation of the system is reduced.

Advantages

- Very simple and cheap method of damping.
- It does not required any permanent magnet.
- Low maintenance.
- It can be mounted horizontally and vertically.

Disadvantages

- This method is suitable for the instruments having weak magnetic field.
Ex- MI instruments, Electro dynamo meter instruments, Watt meter

b. Fluid friction Damping

- In this type of damping, thick oil is used in place of air. As the viscosity of oil is greater, the damping force is also correspondingly greater.
- Here the number of vanes are attached to the spindle which are submerged in the oil.
- Due to friction of the fluid a force is produced, so that the oscillation are reduced accordingly.

Advantages

- This method is suitable for the instruments having low deflecting torque.

Ex- Electro-static Voltmeter

Disadvantages

- These instruments must be placed in vertical position.
- More maintenance is required.

c. Eddy current Damping

- This method of damping is based on the principle that when a current carrying conductor is moved in a magnetic field, an emf is induced in it , which causes a current called eddy current.
- Due to the lenz's law this force is always in opposition to force causing rotation of the conducting material, thus it provide necessary damping .

1.4 Calibration of Instruments.

- Calibration is a comparison between the known measurement and the measurement using measuring instrument.
- The calibration of measuring instruments has two advantages
 - a. It check the accuracy of instruments
 - b. It determine the history, location and application of instruments.

Why calibration is important:-

- The calibration of the instrument is important because it gives the opportunity to check the error and accuracy.
- All measuring instrument must be calibrated against some different instrument which has high accuracy.

CHAPTER- 2 ANALOG AMMETERS AND VOLTMETERS

2.1 Describe Construction, Principle of operation, errors, ranges merits and demerits of:

2.1.1 MOVING IRON TYPE INSTRUMENT

One of the most accurate instruments used for both AC and DC measurement is moving iron instrument.

There are two types of moving iron instrument.

- Attraction type
- Repulsion type

Attraction type M.I. instrument

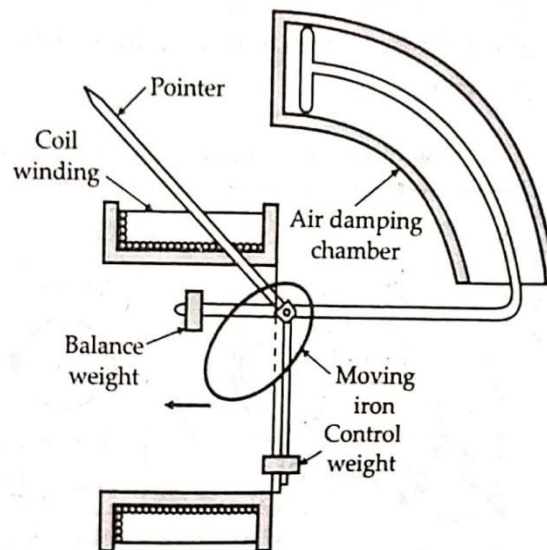

Attraction type moving iron instrument.

Construction:

- It consists of a fixed coil and moving iron piece. The moving iron piece is a flat disc which is mounted on the spindle.
- The controlling torque is provided by either spring control or gravity control.
- Here the damping torque is provided by the Air friction damping.

Working principle:

- When supply is given, then current flow through the fixed coil and magnetic field is produced by Electromagnet.
- Then moving iron piece is attracted by this electromagnet and deflecting torque is produced this attraction force.
- Since the moving iron is attached with the spindle, the spindle rotates and the pointer moves over the scale. But the force of attraction depends on the current flowing through the coil.

Repulsion type M.I. instrument

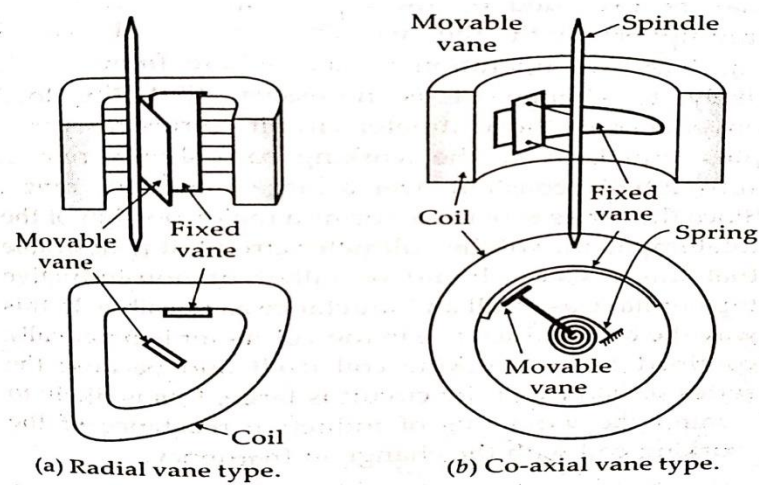

Repulsion type moving iron instruments.

Construction:

- Repulsion type instrument consist of a fixed coil which is wound over the hollow cylinder and two iron pieces that are,
 1. Fixed iron piece
 2. Movable iron piece
- Fixed iron piece is attached to the hollow cylinder and moving iron piece is attached to the spindle.
- Controlling torque is provided by spring control and damping torque is provided by Air friction damping.

Working principle:

- When the instrument is connected to the supply, the current will flow through the fixed coil and the coil will produce a magnetic field surrounding it
- Thus the two iron pieces will be magnetized with similar polarity and repulsion force is produced.
- Due to the repulsion force the movable iron moves the spindles and the pointer start moving from its zero position.

TORQUE EQUATION OF MOVING IRON INSTRUMENTS

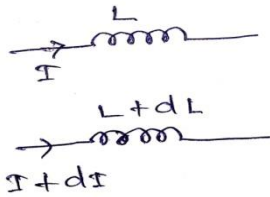

Suppose I = The initial current
 L = instrument inductance
 θ = Angle of deflection

- If the current increases by the 'dI' in 'dt' time then the deflection angle changes by 'dθ', and the inductance changes by 'dL'
- In order to affect the increment 'dI' in the current there must be an increase in the applied voltage given by

$$V = \frac{d}{dt}(LI) = I \frac{dL}{dt} + L \frac{dI}{dt}$$

Electrical energy supplied to coil

$$V \times I \, dt = \left(I \frac{dL}{dt} + L \frac{dI}{dt} \right) \times I \, dt$$

$$V \, I \, dt = \left(I \frac{dL}{dt} \times I \, dt \right) + \left(L \frac{dI}{dt} \times I \, dt \right)$$

$$V \, I \, dt = I^2 \, dL + I \, L \, dI \text{ -----eq. 1}$$

Initially energy store in a coil = $\frac{1}{2} L I^2$

$$\text{Change in stored energy} = \frac{dI}{dt} \left(\frac{1}{2} L I^2 \right)$$

$$= \frac{1}{2} (L \times 2 I \, dI + I^2 \, dL)$$

$$= I \, L \, dI + \frac{1}{2} I^2 \, dL \text{ -----eq.2}$$

Mechanical work done by coil in 'dt' sec

$$= T_d \, d\theta \text{ -----eq.3}$$

From the principle of conservation of energy

Electrical energy supplied = increase in stored energy + mechanical work done

$$\text{Eq. 1} = \text{Eq. 2} + \text{Eq.3}$$

$$I^2 dL + I L dI = I L dI + \frac{1}{2} I^2 dL + T_d d\theta$$

$$I^2 dL - \frac{1}{2} I^2 dL = T_d d\theta$$

$$\frac{1}{2} I^2 dL = T_d d\theta$$

$$T_d d\theta = \frac{1}{2} I^2 dL$$

$$T_d = \frac{1}{2} I^2 \frac{dL}{d\theta}$$

The Spring control method is provided for controlling torque

$$\text{So } T_c = K\theta$$

At Equilibrium Position

$$T_c = T_d$$

$$K\theta = \frac{1}{2} I^2 \frac{dL}{d\theta}$$

$$\theta = \frac{1}{2K} I^2 \frac{dL}{d\theta} \quad (\theta \propto I^2)$$

Advantages:

- MI can be used in AC and DC.
- It is cheap.
- There is no current carrying path in the moving systems hence the instruments are reliable
- Simple construction.
- The Range of instrument can be increased or decreased.

Disadvantages:

- Scale is not uniform. $(\theta \propto I^2)$
- Error due to frequency, stray magnetic field, eddy current and hysteresis error.
- It consumed more power.
- Calibration is different for AC and DC operation.

Error in MI instruments frequency

1. Stray magnetic field error:-

- Due to external magnetic field inside the meter operating field is disturbed. It is called stray magnetic field
- This can be reduced by using an iron case or iron shield over the working part.

2. Frequency error:-

- Change in frequency may causes error.
- Frequency error can be compensated by connecting a suitable capacitor with the reactance.

3. Eddy current error:-

- When the instruments is used for AC measurement, Eddy current is produced in the moving part of the system. This produces an error in the meter reading.

Extension of range of Moving Iron instrument:

MI instrument as an Ammeter (shunt):

- A low shunt resistance is connected in parallel with the ammeter to extent the range of instrument.
- A Large current can be measured in a low rated ammeter by using a shunt.

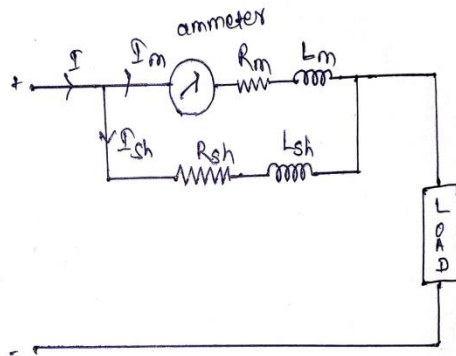

$$Z_{sh} = \frac{Z_m}{m - 1} \quad \text{where } m = \frac{I}{I_m} \quad \& \quad m = \text{Multiplication Factor}$$

MI Instrument as a Voltmeter (Multiplier):

- A large resistance is connected in series with voltmeter is called multiplier.
- A large voltage can be measured in a low rated voltmeter by using multiplier.

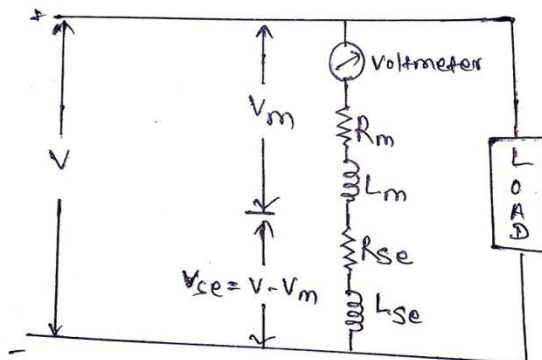

$$Z_{se} = Z_m(m - 1) \quad \text{where } m = \frac{V}{V_m} \quad \& \quad m = \text{Multiplication Factor}$$

SOLVE NUMERICAL

Q.1 The inductance of a moving iron instrument is given by.

$$L = (10 + 5\theta - \theta^2) \mu\text{H}$$

Where θ is the deflection in radian from zero position. The spring constant is 12×10^{-6} N m/rad.

Estimate the deflection for a current of 5A.

ANS:

Given $L = (10 + 5\theta - \theta^2) \mu\text{H}$
 $k = 12 \times 10^{-6}$ N m/rad

So

$$\frac{dL}{d\theta} = (5 - 2\theta) \mu\text{H}$$

we know that

$$\theta = \frac{1}{2} \frac{I^2}{k} \frac{dL}{d\theta}$$

$$\Rightarrow \theta = \frac{1}{2} \frac{(5)^2}{12 \times 10^{-6}} (5 - 2\theta) \times 10^{-6}$$

$$\Rightarrow \theta = \frac{25}{24} (5 - 2\theta) = \frac{125}{24} - \frac{50}{24} \theta$$

$$\Rightarrow \theta + \frac{50}{24} \theta = \frac{125}{24}$$

$$\Rightarrow \theta \left(1 + \frac{50}{24} \right) = \frac{125}{24}$$

$$\Rightarrow \theta \left(\frac{74}{24} \right) = \frac{125}{24}$$

$$\Rightarrow \theta = \frac{125}{74} = 1.69 \text{ rad} = 96.87^\circ$$

$$\Rightarrow \theta = 1.69 \text{ rad or } 96.87^\circ$$

2.1.2 PERMANENT MAGNET MOVING COIL (PMMC) TYPE INSTRUMENTS

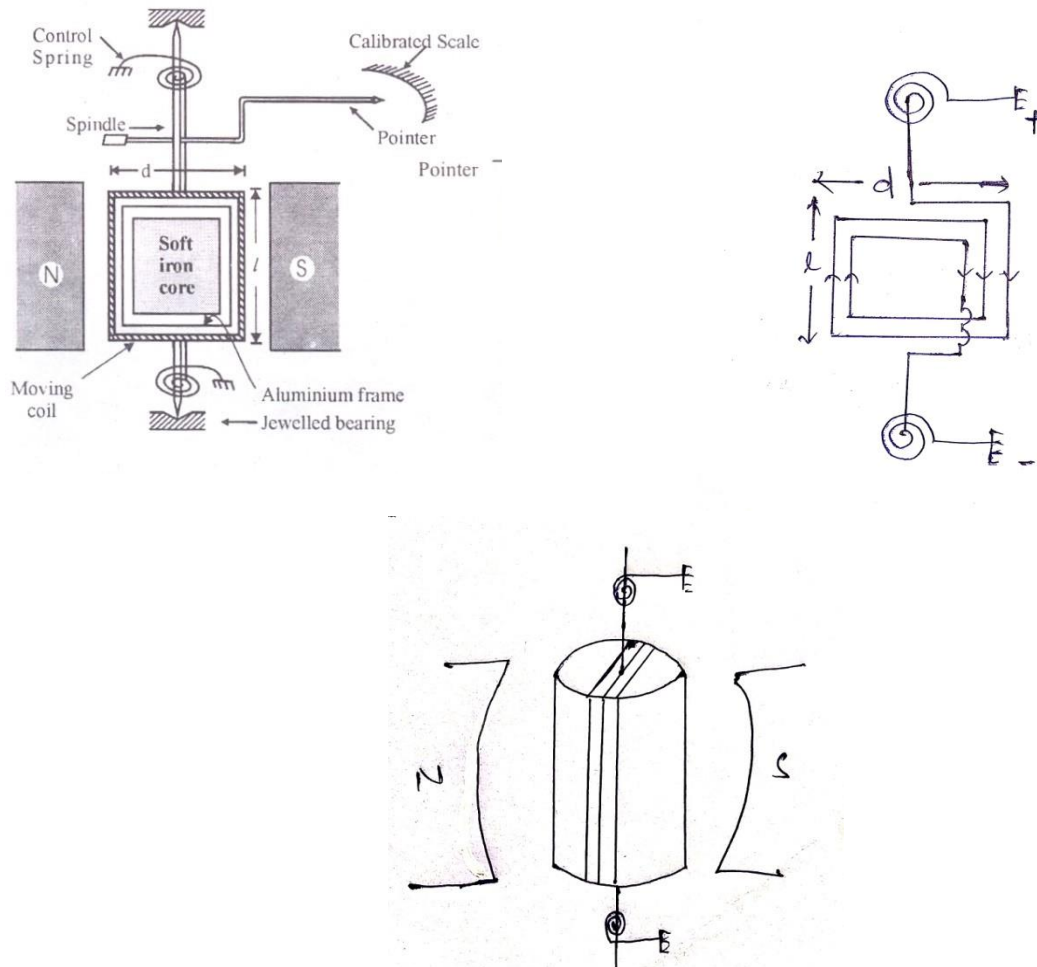

Construction: The PMMC instruments consists of following components:-

1. Permanent Magnet
2. Moving Coil
3. Control Spring
4. Pointer and Scale
5. Jewel Bearing
6. Aluminium Bar

Permanent magnet- A simple permanent magnet is widely used in PMMC instruments which give magnetic field and is made of ALNICO.

Moving coil-

- The moving coil is made up copper, is wound with many turns on the rectangular aluminium former.
- This moving coil is placed inside of permanent magnet and Deflecting Torque (T_d) is produced due to motion of this coil.

Control spring-

- Two control spring made up of phosphor bronze is mounted on the jewel bearing, which are wound in opposite direction to control the pointer movement.

Point and scale-The light weight pointer is attached to the spindle and move over the scale.

Jewel Bearing- Jewel bearing is placed at each side of the spindle to reduce friction.

Aluminium Former-

- Damping torque in PMMC instruments is produced by movement of Aluminium former in the magnetic field of the permanent magnet .
- Due to movement of Aluminium former an Eddy current is developed which produces damping torque known as Eddy current damping.

Principle of operation:

When D.C. supply is given to the moving coil, D.C. current flows through it. According to Lorentz's principle When the current carrying coil is placed in the magnetic field, it experiences a force . This force produces a torque and the former rotates. The pointer is attached with the spindle. When the former rotates, the pointer moves over the calibrated scale in clockwise direction.

TORQUE EQUATION OF MOVING COIL INSTRUMENTS

Let T_d = deflecting torque
 T_C = controlling torque
 θ = angle of deflection
 K = spring constant
 d = width of the coil
 L = length of coil
 N = No. of turns
 I = current flowing in coil
 B = Flux density
 A = area of the coil ($L \times d = A$)

If a current of 'I' ampere is flowing in a coil, Then the force acting on each side of coli is :-

$$F = BIL \sin\theta$$

$$\text{Since } \theta = 90^\circ, \sin 90^\circ = 1$$

$$F = BIL$$

$$\text{For } N \text{ turns, } F = NBIL$$

Deflecting Torque (T_d) = $F \times$ perpendicular distance

$$T_d = NBIL * d = NBI(L*d) .$$

$$T_d = NBIA$$

$$(T_d \propto I)$$

The Spring control method is provided for controlling torque

$$\text{So } T_c = K\theta$$

At Equilibrium Position

$$T_c = T_d$$

$$K\theta = NBIA$$

$$\theta = \frac{NBIA}{K} \quad (\theta \propto I)$$

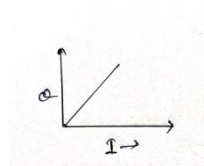

Advantages:-

- Uniform scale. ($\theta \propto I$)
- Eddy current damping is more effective.
- High efficiency
- Range of instrument can be extended.
- No hysteresis loss.
- Very reliable and accurate.

Disadvantages:-

- It cannot be used for AC measurement.
- More expensive than moving iron instruments.
- Error is produced due to ageing effect of PMMC.
- Temperature error is present.

Error in PMMC instruments:

Magnetic flux density:

- Magnetic flux density decreases with weakening of permanent magnet. Due to aging effect, which tends to decrease the deflection of pointer of the instruments.

Due to Spring control:

- The value of Spring control decreases with weakening of spring due to aging effect and temperature effect, which will create an error in pointer deflection.

Due to moving coil:

- The resistance of moving coil is increases with increase in temperature, then the current flowing through the coil decreases accordingly.
- Here the fractional error is reduced by use of ball bearing.

Extension of range of PMMC instrument:

As a DC Ammeter (shunt):

- A low shunt resistance is connected in parallel with the ammeter to extend the range of instrument.
- A Large current can be measured in a low rated ammeter by using a shunt.

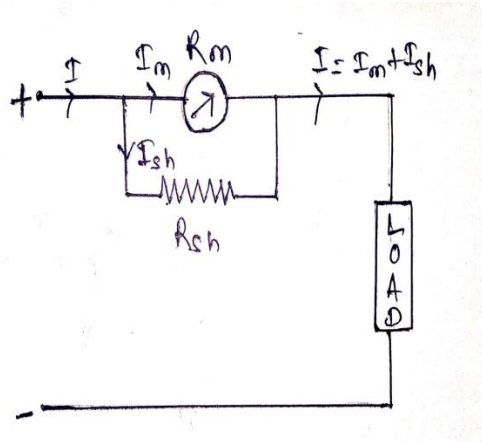

Let R_m = Meter Resistance

R_{sh} = Resistance of shunt

I = Total Current

I_m = Current flow through meter

I_{sh} = current flow through shunt resistance

Since the shunt resistance is in parallel with the meter then the voltage drop across the shunt resistance and voltage drop across the meter must be equal.

$$V_{sh} = V_m$$

$$I_{sh} \times R_{sh} = I_m \times R_m$$

$$R_{sh} = \frac{I_m \times R_m}{I_{sh}}$$

$$R_{sh} = \frac{\frac{I_m \times R_m}{I - I_m}}{\frac{I_m}{I_m}} \quad \text{since } (I_{sh} = I - I_m)$$

$$R_{sh} = \frac{R_m}{\frac{I}{I_m} - 1}$$

$$R_{sh} = \frac{R_m}{m - 1} \quad \text{where } m = \frac{I}{I_m} \quad \& \quad m = \text{Multiplication Factor}$$

As a DC Voltmeter (Multiplier):

- A large resistance is connected in series with voltmeter is called multiplier.
- A large voltage can be measured in a low rated voltmeter by using multiplier.

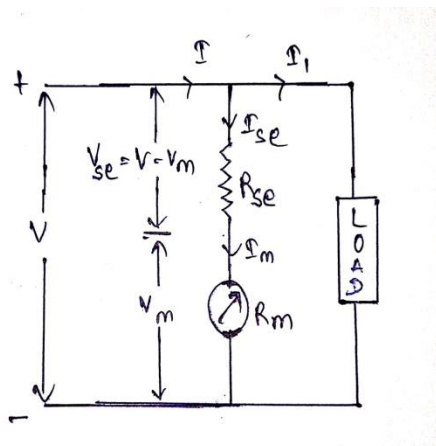

Let R_m = Meter Resistance

R_{se} = resistance of multiplier

V_m = Voltage across meter

V_{se} = Voltage across series resistance

V = Total Voltage

$$I_m = I_{se}$$

$$\frac{V_m}{R_m} = \frac{V_{se}}{R_{se}}$$

$$\frac{V_m}{R_m} = \frac{V - V_m}{R_{se}}$$

$$R_{se} = \frac{R_m (V - V_m)}{V_m}$$

$$R_{se} = R_m \left(\frac{V}{V_m} - 1 \right)$$

$$R_{se} = R_m (m - 1) \quad \text{where } m = \frac{V}{V_m} \text{ \& } m = \text{Multiplication Factor}$$

SOLVE NUMERICAL

Q.1 A 1 mA ammeter has its internal resistance of 100Ω is to be converted into a 0-100 mA ammeter. Calculate the shunt resistance and total resistance of circuit.

ANS:- Given $R_m = 100 \Omega$, $I_m = 1 \text{ mA}$, $I = 100 \text{ mA}$

$$\text{Then multiplication Factor } (m) = \frac{I}{I_m} = \frac{100 \text{ mA}}{1 \text{ mA}} = 100$$

$$R_{sh} = \frac{R_m}{m - 1} = \frac{100 \Omega}{100 - 1} = 1.01 \Omega$$

$$\text{Total resistance of circuit} = \frac{R_m \times R_{sh}}{R_m + R_{sh}} = \frac{100 \times 1.01}{100 + 1.01} = 0.99 \Omega$$

Q.2 A moving-coil instrument whose resistance is 25Ω gives a full scale deflection with a voltage of 25 mV . This instrument is to be used with a series multiplier to extend its range to 10 V . Calculate multiplication factor, series resistance and total resistance of voltmeter circuit.

ANS:- Given $R_m = 25 \Omega$, $V_m = 25 \text{ mV}$, $V = 10 \text{ V}$

$$\text{Then multiplication Factor (m)} = \frac{V}{V_m} = \frac{10 \text{ V}}{25 \text{ mV}} = 400$$

$$R_{se} = R_m(m - 1) = 25(400 - 1) = 9975 \Omega$$

$$\text{Total resistance of circuit} = R_m + R_{se} = 25 + 9975 = 10000 \Omega$$

Q.3 A 0 to 10 mV voltmeter has its internal resistance of 1Ω . Then its range is extended to 50 A . Then required shunt resistance is ?

ANS:- Given $V_m = 10 \text{ mV}$, $R_m = 1 \Omega$, $I = 50 \text{ A}$

$$I_m = \frac{V_m}{R_m} = \frac{10 \text{ mV}}{1 \Omega} = 10 \text{ mA}$$

$$\text{Then multiplication Factor (m)} = \frac{I}{I_m} = \frac{50 \text{ A}}{10 \text{ mA}} = 5000$$

$$R_{sh} = \frac{R_m}{m - 1} = \frac{1 \Omega}{5000 - 1} = 20 \text{ m}\Omega$$

Q.4 Find the multiplication factor of a shunt of 200Ω resistance used with a galvanometer of 1000Ω resistance. Determine the value of shunt resistance to give a multiplication factor of 50 .

ANS:- Given $R_m = 1000 \Omega$, $R_{sh} = 200 \Omega$

$$\text{Then multiplication Factor (m)} = 1 + \frac{R_m}{R_{sh}} = 1 + \frac{1000}{200} = 6$$

$$\text{We have } m = 1 + \frac{R_m}{R_{sh}}$$

For $m = 50$

$$R_{sh} = \frac{R_m}{m - 1} = \frac{1000 \Omega}{50 - 1} = 20.4 \Omega$$

2.1.3 ELECTRODYNAMOMETER TYPE INSTRUMENTS

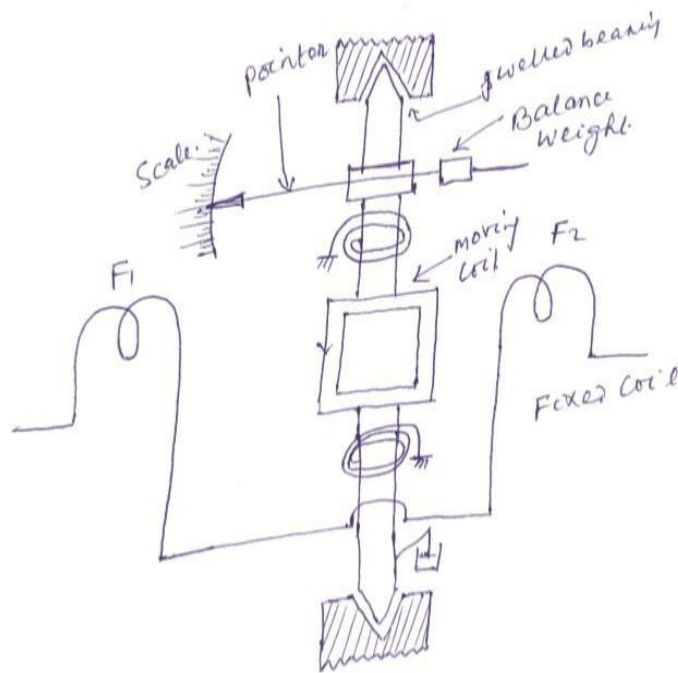

Construction:- The main parts of Dynamometer type instruments are :-

1. Fixed Coil
2. Moving Coil
3. Controlling system
4. Damping system
5. Pointer and Scale

A fixed coil is divided into two equal halves. The moving coil is placed between the two halves of the fixed coil. Both the fixed and moving coils are air cored. So that the hysteresis effect will be zero. The pointer is attached with the spindle. In a non-metallic former the moving coil is wound. Spring is used for controlling torque. Air friction damping is used for damping torque.

Principle of operation:-

- When the dynamometer type instrument is connected to the supply, the operating current flows through the fixed coil and moving coil.
- According to the Lorentz principle, a mechanical torque is produced on the moving coil which is placed inside the magnetic field produced by the fixed coil.
- Due to the moment of moving coil, the spindle will move and then the pointer starts to move over the scale.

TORQUE EQUATION OF ELECTRODYNAMOMETER TYPE INSTRUMENTS

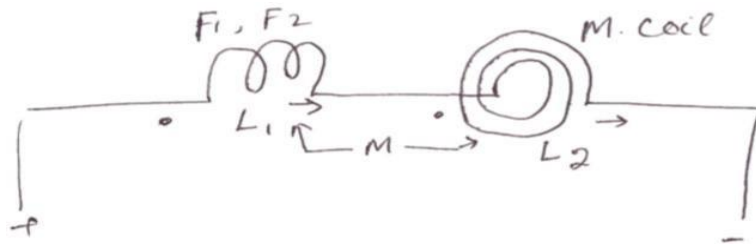

Let

L_1 = Self inductance of fixed coil

L_2 = Self inductance of moving coil

M = mutual inductance between fixed coil and moving coil

I_1 = current through fixed coil

I_2 = current through moving coil

θ = Angle between I_1 and I_2

Total inductance of system (L_{Total}) = $L_1 +$

$L_2 + 2M$

Operation with D.C

$$T_d = I_1 I_2 \frac{dM}{d\theta}$$

\therefore Controlling torque
 $T_c = k\theta$

At equilibrium position

$$T_c = T_d$$

$$\Rightarrow k\theta = I_1 I_2 \frac{dM}{d\theta}$$

$$\Rightarrow \theta = \frac{I_1 I_2}{k} \frac{dM}{d\theta}$$

Operation with A.C

$$T_d = I_1 I_2 \cos\phi \frac{dM}{d\theta}$$

\therefore controlling torque
 $T_c = k\theta$

At equilibrium position

$$T_c = T_d$$

$$\Rightarrow k\theta = I_1 I_2 \cos\phi \frac{dM}{d\theta}$$

$$\Rightarrow \theta = \frac{I_1 I_2 \cos\phi}{k} \frac{dM}{d\theta}$$

Advantages:-

- This instrument can be used on both A.C and D.C
- It can be used as voltmeter, ammeter and wattmeter.
- As the coils are air cored, so Hysteresis and eddy current error is negligible.
- Damping is effective

Disadvantages:-

- Scale is not uniform.
- Cost is more.
- Error is produced due to frequency, temperature and stray field.

Dynamometer type instrument use as Ammeter

- To convert a Dynamometer into ammeter, both fixed coil and moving coils are connected in series and the whole combination is connected in series with load.

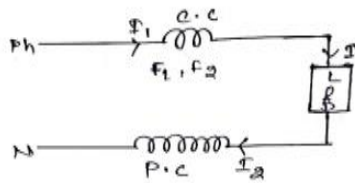

$$T_d = I_1 I_2 \cos \phi \frac{dM}{d\theta}$$

In this case

$$I_1 = I_2 = I$$

$$\therefore \phi = 0$$

$$\cos \phi = 1$$

$$\therefore T_d = I \cdot I \cdot 1 \frac{dM}{d\theta}$$

$$\Rightarrow \boxed{T_d = I^2 \frac{dM}{d\theta}}$$

Controlling torque (Spring control)

$$T_c = k\theta$$

At equilibrium position

$$T_c = T_d$$

$$\Rightarrow k\theta = I^2 \frac{dM}{d\theta}$$

$$\Rightarrow \boxed{\theta = \frac{I^2}{k} \frac{dM}{d\theta}}$$

($\theta \propto I^2 \rightarrow$ Non linear)
or
Non-uniform scale

Dynamometer type instrument use as Voltmeter

- To convert a Dynamometer into voltmeter, both fixed coil and moving coils are connected in series and the whole combination is connected in parallel with load.

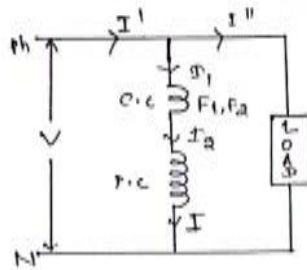

$$T_d = I_1 I_2 \cos \phi \frac{dM}{d\theta}$$

$$I_1 = I_2 = I = \frac{V}{Z}$$

and $\phi = 0$,

$$\cos \phi = 1$$

$$\Rightarrow T_d = \frac{V}{Z} \cdot \frac{V}{Z} \cdot L \frac{dM}{d\theta}$$

$$\Rightarrow \boxed{T_d = \frac{V^2}{Z^2} \frac{dM}{d\theta}}$$

controlling torque (spring control)

$$T_c = k\theta$$

At equilibrium position

$$T_c = T_d$$

$$\Rightarrow k\theta = \frac{V^2}{Z^2} \frac{dM}{d\theta}$$

$$\Rightarrow \boxed{\theta = \frac{V^2}{k \cdot Z^2} \frac{dM}{d\theta}}$$

($\theta \propto V^2 \rightarrow$ scale is non-uniform)

Dynamometer type instrument use as Wattmeter

- To convert a Dynamometer into wattmeter, the fixed coil (Current coil) is connected in series with load and moving coils (Pressure coil) is connected in parallel with load and current coil.

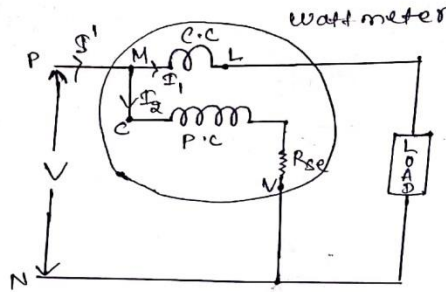

$$T_d = I_1 I_2 \cos \phi \frac{dM}{d\alpha}$$

Here, $I_1 \neq I_2$

Let $I_1 = I$

$$I_2 = \frac{V}{Z}$$

$$\text{So } T_d = I \cdot \frac{V}{Z} \cdot \cos \phi \frac{dM}{d\alpha}$$

$$\Rightarrow T_d = \frac{V I \cos \phi}{Z} \frac{dM}{d\alpha}$$

Controlling Torque (spring control)

$$T_c = k\alpha$$

At equilibrium position

$$T_c = T_d$$

$$\Rightarrow k\alpha = \frac{V I \cos \phi}{Z} \frac{dM}{d\alpha}$$

$$\Rightarrow \alpha = \frac{V I \cos \phi}{k \cdot Z} \frac{dM}{d\alpha}$$

2.1.4 Rectifier Type Instruments

- The instruments which use the rectifying elements for measurements of voltage and current is known as rectifying instruments.
- The rectifying elements convert the alternating current (A.C) to direct current (D.C) which measure by the PMMC instruments.
- This instruments is of 2 types :-
 - (a) Half wave rectifier Instrument
 - (b) Full wave rectifier Instrument

(a) Half wave rectifier Instrument:-

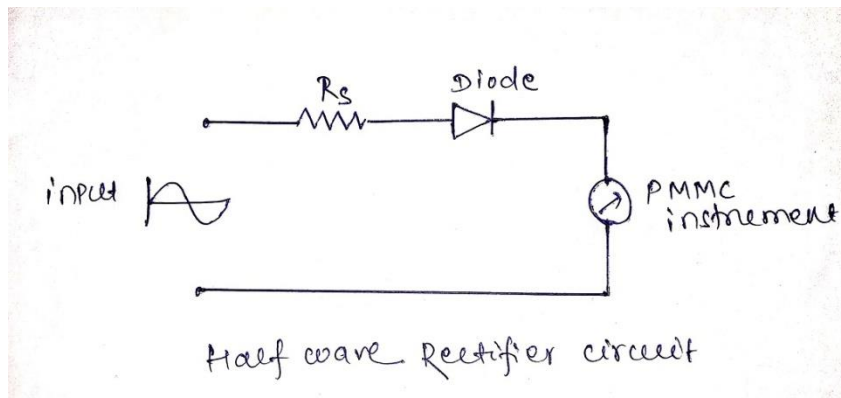

- In this circuit a rectifying elements diode (D) is connected in series with sinusoidal voltage source, PMMC instruments and multiplier resistance (R_s).
- The function of resistance is to limit the current drawn by PMMC instruments.

Let R_s = Multiplier Resistance

R_m = Meter resistance

Case-I

When D.C supply is applied to the circuit, current through the meter is

$$I = \frac{V}{R_s + R_m}$$

Where, I = Full scale deflection current

Case-II

- When A.C supply is applied to the circuit, a unidirectional pulsating voltage is produced at the output of rectifier. This pulsating voltage produces a pulsating current and hence a pulsating torque is developed.

- PMMC indicates a deflection corresponding to average value of current which is depends on the average value of applied voltage.

Average value of voltage

$$V_{av} = \frac{1}{2\pi} \int_0^{\pi} V_m \sin \omega t \, d(\omega t)$$

$$= \frac{V_m}{2\pi} [-\cos \omega t]_0^{\pi}$$

$$= \frac{V_m}{2\pi} [-\cos \pi + \cos 0]$$

$$= \frac{V_m}{2\pi} [-(-1) + 1]$$

$$\Rightarrow V_{av} = \frac{V_m}{2\pi} (1+1) = \frac{V_m}{2\pi} \times 2 = \frac{V_m}{\pi}$$

$$\Rightarrow \boxed{V_{av} = \frac{V_m}{\pi}}$$

(b) Full wave rectifier Instrument:-

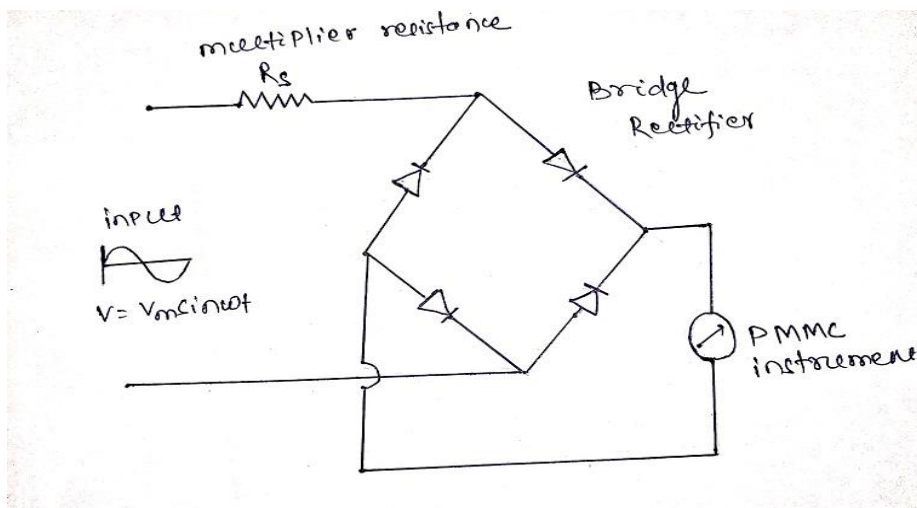

Case-I

When D.C supply is applied to the circuit, current through the meter is

$$I = \frac{V}{R_s + R_m}$$

Where, I = Full scale deflection current

Case-II

- When sinusoidal voltage $V = V_m \sin \omega t$ is applied to the circuit, then the average voltage across the meter is

Average value of voltage

$$V_{av} = \frac{1}{\pi} \int_0^{\pi} V_m \sin \omega t \, d(\omega t)$$

$$= \frac{V_m}{\pi} \left[-\cos \omega t \right]_0^{\pi}$$

$$= \frac{V_m}{\pi} \left[-\cos \pi + \cos 0 \right]$$

$$= \frac{V_m}{\pi} \left[-(-1) + 1 \right]$$

$$\Rightarrow V_{av} = \frac{V_m}{\pi} (1+1) = \frac{V_m}{\pi} \times 2$$

$$\Rightarrow \boxed{V_{av} = \frac{2V_m}{\pi}}$$

CHAPTER-3 WATTMETERS AND MEASUREMENTS OF POWER

3.1 DYNAMOMETER TYPE WATTMETER (LPF AND UPF TYPE)

Construction:-

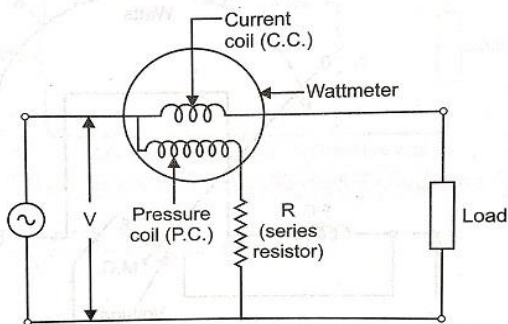
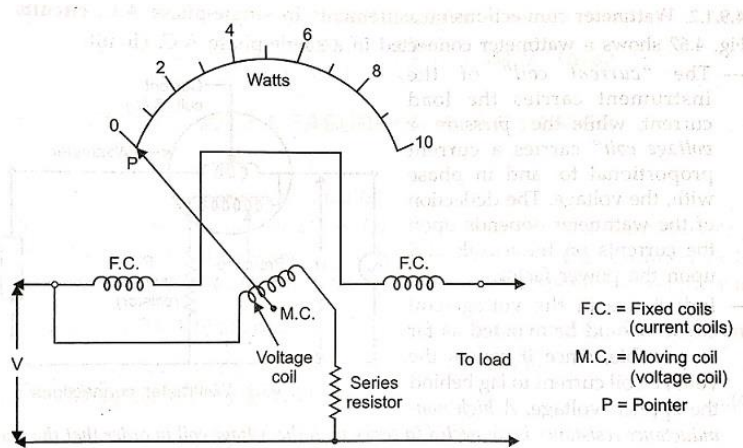

- It is the modified form of both PMMC and MI instruments.
- The main parts of Dynamometers type wattmeter are:-
 1. Fixed Coils
 2. Moving Coils
 3. Control System
 4. Damping System
 5. Scale & Pointer

1. Fixed Coil :-

- The magnetic field is produced by a fixed coil which is again divided into two sections which give more uniform flux to the centre.
- The two fixed coils are air cored to avoid hysteresis loss when used in AC.
- The fixed coils are connected in series with the load so the current in the fixed coil is proportional to the load current.
- Fixed coils are made up of a few nos. of turns with thick wire.

2. Moving Coil:-

- It consists of more nos. of turns with thin wire which is placed in between the two fixed coil.
- The moving coil is connected across the load and therefore the current in moving coil is proportional to supply voltage.

3.Control System:-

- The controlling torque is provided by two controlling spring.

4.Damping System:-

- The damping torque is provided by the air friction damping.

5.Scale & Pointer:-

- The light weight pointer is attached to the spindle and moves over the scale.
- It is made up of aluminium.

Principle of operation:-

- When a current carrying moving coil is placed in a magnetic field produced by the current carrying fixed coil, a mechanical force is exerted in the moving coil.
- Due to this mechanical force, the spindle deflect and the pointer moves over the scale.

TORQUE EQUATION OF ELECTRODYNAMOMETER TYPE WATTMETER

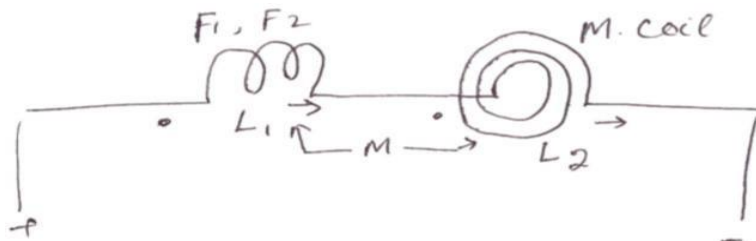

Let

L_1 = Self inductance of fixed coil

L_2 = Self inductance of moving coil

M = mutual inductance between fixed coil and moving coil

I_1 = current through fixed coil

I_2 = current through moving coil

ϕ = Angle between I_1 and I_2

Total inductance of system (L_{Total}) = $L_1 +$

$L_2 + 2M$

Operation with D.C

$$T_d = F_1 F_2 \frac{dM}{d\theta}$$

\therefore Controlling torque
 $T_c = k\theta$

At equilibrium position

$$T_c = T_d$$

$$\Rightarrow k\theta = F_1 F_2 \frac{dM}{d\theta}$$

$$\Rightarrow \theta = \frac{F_1 F_2}{k} \frac{dM}{d\theta}$$

Operation with A.C

$$T_d = I_1 I_2 \cos \phi \frac{dM}{d\alpha}$$

$$\Rightarrow T_d = I \frac{V}{R} \cos \phi \frac{dM}{d\alpha} \quad \left(\because \begin{array}{l} I_1 = I \\ I_2 = \frac{V}{R} \end{array} \right)$$

$$\Rightarrow T_d = \frac{VI \cos \phi}{R} \frac{dM}{d\alpha}$$

\therefore controlling torque
 $T_c = k\alpha$

At equilibrium position

$$T_c = T_d$$

$$\Rightarrow k\alpha = \frac{VI \cos \phi}{R} \frac{dM}{d\alpha}$$

$$\Rightarrow \alpha = \frac{VI \cos \phi}{Rk} \frac{dM}{d\alpha}$$

$$\Rightarrow \alpha = \left(\frac{1}{Rk} \frac{dM}{d\alpha} \right) VI \cos \phi$$

$$\Rightarrow \alpha = \left(k_1 \frac{dM}{d\alpha} \right) P$$

where $k_1 = \frac{1}{Rk}$

$P =$ average power to be measured

$$P = VI \cos \phi$$

$$\Rightarrow \boxed{\alpha \propto P}$$

Advantages:

- It can be used for both AC and DC circuit.
- It has a uniform scale.
- High Accuracy.

Disadvantages:

- Reading may be effected by stray magnetic field .
- Error occurs due to the inductance of pressure coil.

The various type of error in dynamometer type wattmeter are,

- (a) Error due to pressure coil inductance
- (b) error due to pressure coil capacitance
- (c) error due to a eddy current
- (d) error due to temperature
- (e) error due to connection
- (f) error due to stray magnetic field

(a)Error due to pressure coil inductance:-

- Due to the pressure coil inductance the current lags the voltage by an angle ' θ '. Hence power factor becomes lagging and leads to a high reading.
- Inductance of the pressure coil can be reduced by means of a capacitor connected in parallel with a portion of the resistor.

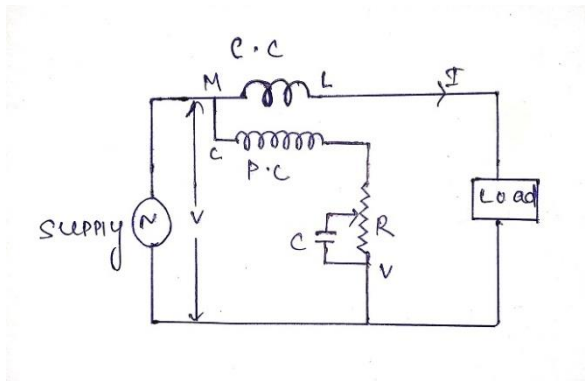

(b)Error due to pressure coil capacitance:-

- The pressure coil also have capacitance. So due to high value of capacitance, the effect of capacitor tends to lead the current by the applied voltage which may produce error in reading.
- This error can be minimised, if the capacitive reactance is equal to the inductive reactance.

(c)Error due to Eddy current:-

- The eddy currents induced in the solid metal parts of the instrument, by the alternating magnetic field produced by the current coil, change the magnitude and phase of this field and so produce an error.
- This error can be reduced by using stranded conductor.

(d)Error due to Temperature:-

- The wattmeter is affected by any change in temperature, there will be a change in resistance of the pressure coil and stiffness of the spring.
- This effect can be eliminated by the the pressure coil made up of copper and resistance made up of manganin having negligible temperature coefficient.

(e)Error due to connection:-

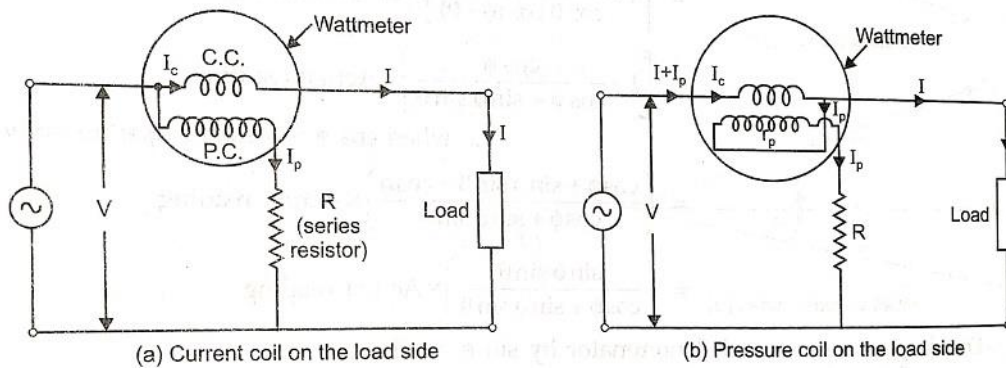

- These errors are due to the alternative connections of wattmeter. In general the wattmeter having 'M-C' connection. If 'L-C' points are short, then the current coil carry more current so more flux will be produced.
- So to eliminate that error, a compensating coil is used with the current coil.

(f)Error due to stray magnetic field:-

- The main magnetic field is disturbed due to external magnetic field resulting in the serious errors.
- This errors can be reduced by using iron case or iron shield over the working part.

3.2 INDUCTION TYPE WATTMETER

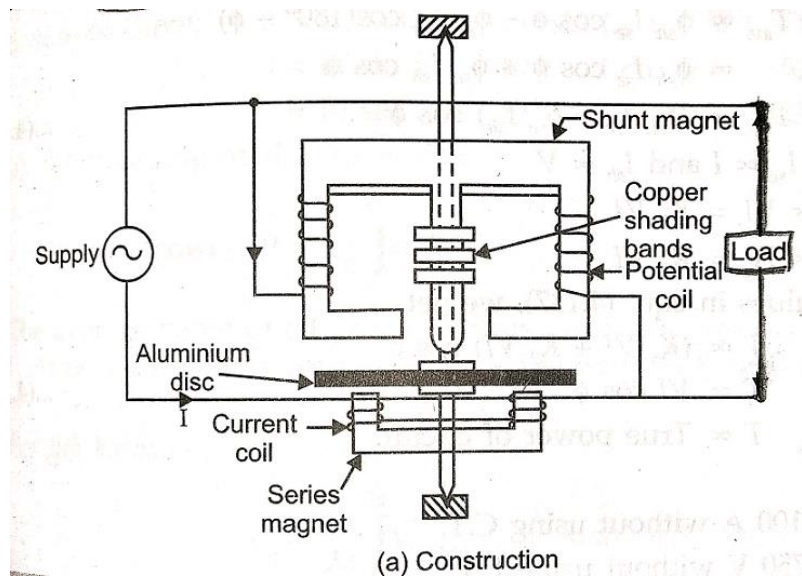

- It consists of two laminated electromagnet called as shunt electromagnet and series electromagnet.
- The coil of the Shunt electromagnet is highly inductive so that the current lags behind the supply voltage by an angle 90° .
- The coil of the series electromagnet is made up of highly non-inductive metal so that the angle between voltage and current is fully determined by the load current.
- A thin aluminium disc mounted on the spindle, placed in between the two electromagnet so that it cuts the magnetic flux produced by the electromagnet.
- The controlling torque is provided by the spring control mechanism.
- Two or more copper shaded rings are provided on the central limb of the shunt magnet.

Working principle

- When the watt meter is connected in the circuit to measure the AC power, the shunt magnet carries the current proportional to the supply voltage and the series magnet carries current proportional to the load current.
- These two currents produce two fluxes and these two fluxes produce two eddy currents in the aluminium disc.
- Due to the interaction between the two fluxes and two eddy currents, the deflecting torque is produced in the aluminium disc which causes rotation of the spindle and pointer.

TORQUE EQUATION OF INDUCTION TYPE WATTMETER

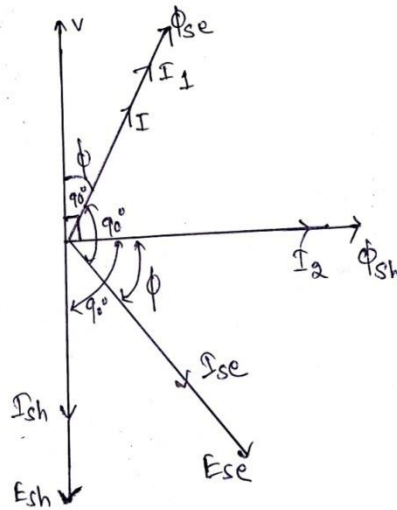

Phasor diagram

Let,

V = supply voltage

I = Load current

I_1 = current carries by series magnet

I_2 = current carries by shunt magnet

ϕ = Phase angle between load current and voltage

ϕ_{se} = Flux produced by series magnet

ϕ_{sh} = Flux produced by shunt magnet

E_{sh} = Emf induced in the disc by the shunt magnet flux

E_{se} = Emf induced in the disc by the series magnet flux

I_{se} = Eddy current in the disc caused by emf E_{se}

I_{sh} = Eddy current in the disc caused by emf E_{sh}

- The current I_2 flow through the shunt magnet is proportional to the supply voltage and lags the voltage by an angle 90° . (Shunt magnet having high inductance due to more number of turns)
- The current I_1 flow through the series magnet is proportional to the load current and lags the voltage by an angle ϕ .
- The flux ϕ_{se} produced by the current I_1 is in phase with it, similarly the flux ϕ_{sh} produced by I_2 is also in phase with it.

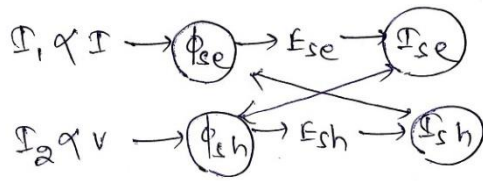

$$T_{d1} = \phi_{sh} \cdot \Phi_{se} \cos(\phi_{sh} \& \Phi_{se})$$

$$= \phi_{sh} \cdot \Phi_{se} \cos \phi$$

$$T_{d2} = \phi_{se} \cdot \Phi_{sh} \cos(\phi_{se} \& \Phi_{sh})$$

$$= \phi_{se} \cdot \Phi_{sh} \cos(180 - \phi)$$

since, the phase angle between ϕ_{sh} & Φ_{se} is ϕ , and phase angle between ϕ_{se} and Φ_{sh} is $(180 - \phi)$, therefore,

$$\text{Average torque, } T_{av} \propto \phi_{sh} \Phi_{se} \cos \phi - \phi_{se} \Phi_{sh} \cos(180 - \phi)$$

$$\Rightarrow T_{av} \propto \phi_{sh} \Phi_{se} \cos \phi + \phi_{se} \Phi_{sh} \cos \phi$$

$$\Rightarrow T_{av} \propto (\phi_{sh} \Phi_{se} + \phi_{se} \Phi_{sh}) \cos \phi$$

$$\text{since } \phi_{sh} \propto V, \phi_{se} \propto I$$

$$\Phi_{se} \propto I \text{ and } \Phi_{sh} \propto V$$

$$\phi_{sh} \Phi_{se} \propto V I = k_1 V I$$

$$\phi_{se} \Phi_{sh} \propto V I = k_2 V I$$

$$\Rightarrow T_{av} \propto (k_1 V I + k_2 V I) \cos \phi$$

$$\Rightarrow T_{av} \propto (k_1 + k_2) V I \cos \phi \propto K V I \cos \phi$$

$$\Rightarrow T_{av} \propto V I \cos \phi$$

$$\Rightarrow T_{av} \propto \text{true power of circuit}$$

Difference between Dynamometer type wattmeter and Induction type wattmeter

Dynamometer type wattmeter

1. It can be used for both AC and DC measurement.
2. Air friction damping is used.
3. It consume less power.

Induction type wattmeter

1. It can be used only for AC
2. Eddy current damping is used.
3. It consume more power.

MEASUREMENT OF POWER IN 3-PHASE CIRCUITS

There are three methods are used for measurement of power in three phase circuit

- (a) 3- wattmeter method
- (b) 2- wattmeter method
- (c) 1-wattmeter method

Generally 2-wattmeter method is used for measurement of power in both balanced and unbalanced load

MEASUREMENT OF POWER IN 3-PHASE CIRCUITS BY USING THREE WATTMETER METHOD

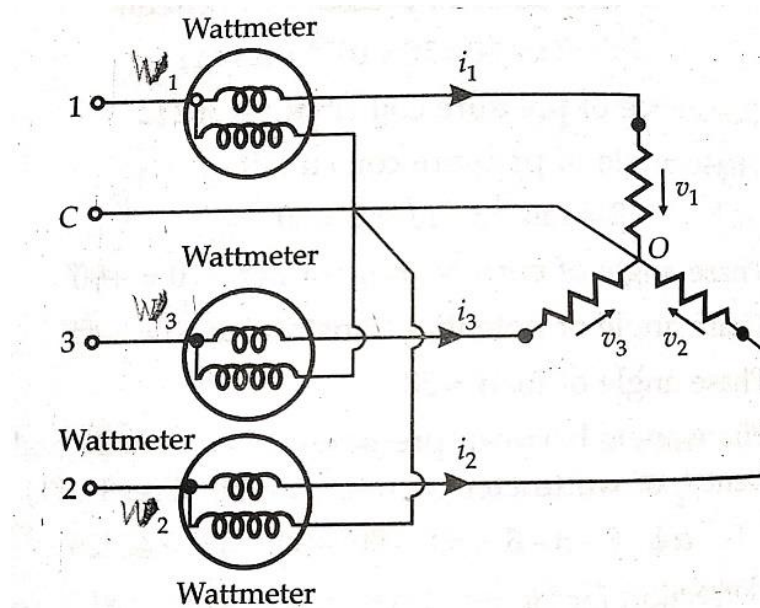

- In this method, there are three wattmeters W_1 , W_2 , and W_3 are used in each phase of the supply voltage.
- So the total instantaneous power is given by the algebraic sum of the reading of 3 wattmeters.

$$\text{Total power } (P_T) = W_1 + W_2 + W_3$$

MEASUREMENT OF POWER IN 3-PHASE CIRCUITS BY USING TWO WATTMETER METHOD

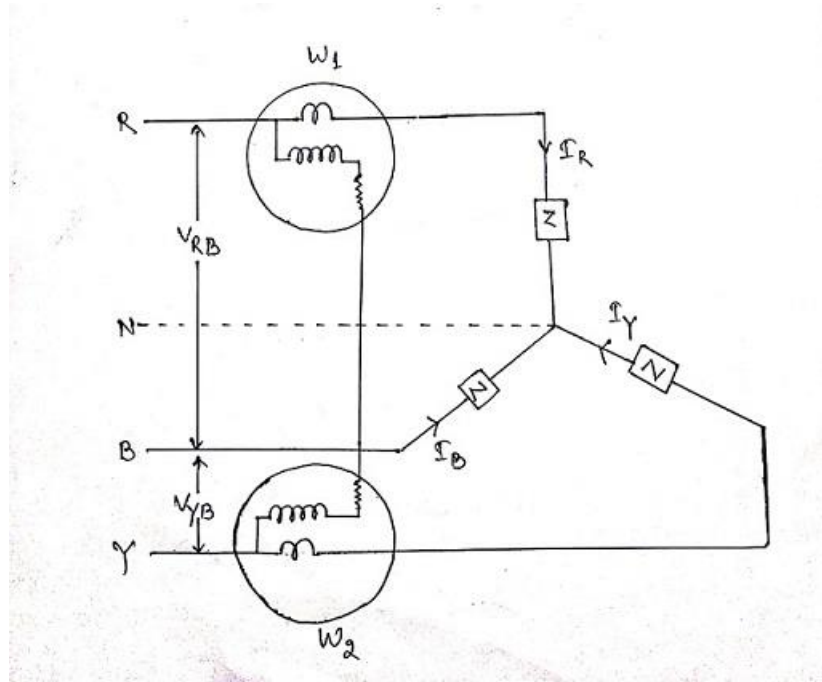

Two wattmeter method (star connection)

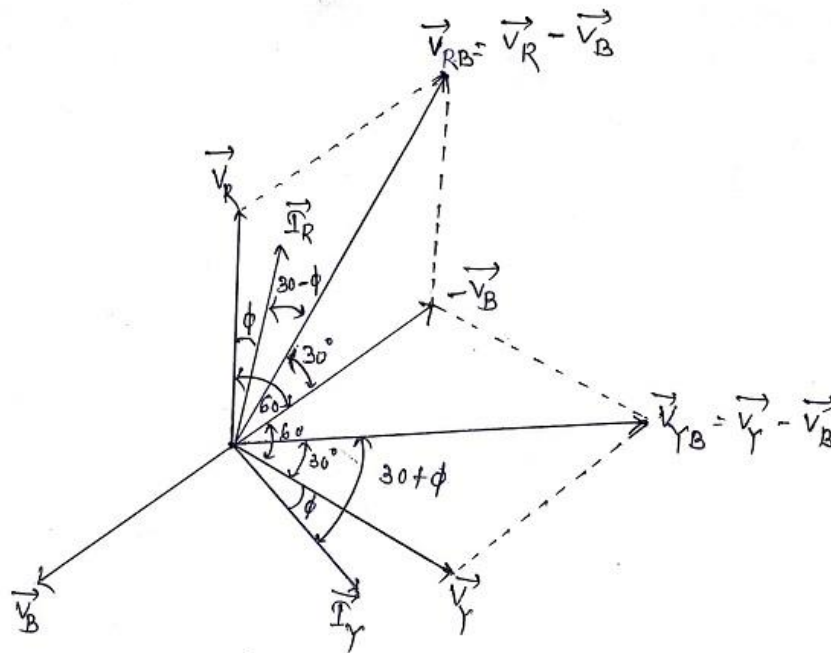

Phasor diagram

$$\text{Voltage across } w_1 = \vec{V}_{RB} = \vec{V}_R - \vec{V}_B$$

$$\text{Current through } w_1 = \vec{I}_R$$

$$\text{Phase difference between } \vec{V}_{RB} \text{ \& } \vec{I}_R = 30 - \phi$$

$$\text{Similarly voltage across } w_2 = \vec{V}_{YB} = \vec{V}_Y - \vec{V}_B$$

$$\text{Current through } w_2 = \vec{I}_Y$$

$$\text{Phase difference between } \vec{V}_{YB} \text{ \& } \vec{I}_Y = 30 + \phi$$

∴ Reading of w_1 wattmeter,

$$W_1 = \vec{V}_{RB} \cdot \vec{I}_R \cos [\vec{V}_{RB} \text{ \& } \vec{I}_R]$$

$$W_1 = \vec{V}_{RB} \cdot \vec{I}_R \cos (30 - \phi)$$

and Reading of w_2 wattmeter

$$W_2 = \vec{V}_{YB} \cdot \vec{I}_Y \cos [\vec{V}_{YB} \text{ \& } \vec{I}_Y]$$

$$W_2 = \vec{V}_{YB} \cdot \vec{I}_Y \cos (30 + \phi)$$

At Balanced load,

$$\vec{V}_{RB} = \vec{V}_{YB} = V_L \text{ (line voltage)}$$

$$\vec{I}_R = \vec{I}_Y = I_L \text{ (line current)}$$

$$\text{So } w_1 = V_L I_L \cos(30 - \phi)$$

$$w_2 = V_L I_L \cos(30 + \phi)$$

So Total power consumed by load,

$$w = w_1 + w_2$$

$$\Rightarrow w_1 + w_2 = V_L I_L \cos(30 - \phi) + V_L I_L \cos(30 + \phi)$$

$$\Rightarrow w_1 + w_2 = V_L I_L [\cos(30 - \phi) + \cos(30 + \phi)]$$

$$\Rightarrow w_1 + w_2 = V_L I_L (2 \cdot \cos 30 \cdot \cos \phi)$$

$$\Rightarrow w_1 + w_2 = V_L I_L \cdot 2 \cdot \frac{\sqrt{3}}{2} \cdot \cos \phi$$

$$\Rightarrow \boxed{w_1 + w_2 = \sqrt{3} V_L I_L \cos \phi} \longrightarrow \text{eq}^n \text{ (1)}$$

Difference of Reading of two wattmeters

$$w_1 - w_2 = V_L I_L \cos(30 - \phi) - V_L I_L \cos(30 + \phi)$$

$$\Rightarrow w_1 - w_2 = V_L I_L [\cos(30 - \phi) - \cos(30 + \phi)]$$

$$\Rightarrow w_1 - w_2 = V_L I_L (2 \cdot \sin 30 \cdot \sin \phi)$$

$$\Rightarrow w_1 - w_2 = V_L I_L \cdot 2 \cdot \frac{1}{2} \cdot \sin \phi$$

$$\Rightarrow \boxed{w_1 - w_2 = V_L I_L \sin \phi} \longrightarrow \text{eq}^n \text{ (2)}$$

Now

$$\frac{\text{eq}^n \text{ (2)}}{\text{eq}^n \text{ (1)}} = \frac{w_1 - w_2}{w_1 + w_2} = \frac{V_L I_L \sin \phi}{\sqrt{3} V_L I_L \cos \phi} = \frac{\tan \phi}{\sqrt{3}}$$

$$\Rightarrow \frac{w_1 - w_2}{w_1 + w_2} = \frac{\tan \phi}{\sqrt{3}}$$

$$\Rightarrow \tan \phi = \sqrt{3} \left(\frac{w_1 - w_2}{w_1 + w_2} \right)$$

$$\Rightarrow \boxed{\phi = \tan^{-1} \left[\sqrt{3} \left(\frac{w_1 - w_2}{w_1 + w_2} \right) \right]}$$

ϕ = phase angle of load

$$\Rightarrow \boxed{\cos \phi = \cos \left[\tan^{-1} \left(\sqrt{3} \left(\frac{w_1 - w_2}{w_1 + w_2} \right) \right) \right]}$$

P.F. of load

EFFECT OF POWER FACTOR ON THE READING OF WATTMETERS

$$W_1 = V_L I_L \cos(30 - \phi)$$

$$W_2 = V_L I_L \cos(30 + \phi)$$

(a) with unity p.f, $\cos\phi = 1$, and $\phi = 0$

$$W_1 = V_L I_L \cos(30 - \phi)$$

$$= V_L I_L \cos(30 - 0)$$

$$= V_L I_L \cos 30^\circ$$

$$= V_L \cdot I_L \cdot \frac{\sqrt{3}}{2}$$

$$W_1 = \frac{\sqrt{3} V_L I_L}{2}$$

$$W_2 = V_L I_L \cos(30 + \phi)$$

$$= V_L I_L \cos(30 + 0)$$

$$= V_L I_L \cos 30^\circ$$

$$= V_L \cdot I_L \cdot \frac{\sqrt{3}}{2}$$

$$W_2 = \frac{\sqrt{3} V_L I_L}{2}$$

$$W_1 = W_2$$

Thus at unity power factor, the readings of the two wattmeters are equal.

(b) when $\cos\phi = 0.86$ (lag), $\phi = 30^\circ$

$$W_1 = V_L I_L \cos(30 - \phi)$$

$$= V_L I_L \cos(30 - 30^\circ)$$

$$= V_L I_L \cos 0^\circ$$

$$= V_L I_L \cdot 1$$

$$W_1 = V_L I_L$$

$$W_2 = V_L I_L \cos(30 + \phi)$$

$$= V_L I_L \cos(30 + 30)$$

$$= V_L I_L \cos 60^\circ$$

$$= V_L \cdot I_L \cdot \frac{1}{2}$$

$$W_2 = \frac{V_L I_L}{2}$$

$$W_1 = 2 W_2$$

Therefore, when the power factor is 0.86, the readings of one wattmeter is half of other wattmeter's readings.

(c) when $\cos \phi = 0.5$ (lag), $\phi = 60^\circ$

$$W_1 = V_L I_L \cos(30 - \phi)$$

$$= V_L I_L \cos(30 - 60^\circ)$$

$$= V_L I_L \cos(-30^\circ)$$

$$= V_L I_L \cos 30^\circ$$

$$= V_L I_L \frac{\sqrt{3}}{2}$$

$$W_1 = \frac{\sqrt{3} V_L I_L}{2}$$

$$W_2 = V_L I_L \cos(30 + \phi)$$

$$= V_L I_L \cos(30 + 60)$$

$$= V_L I_L \cos 90^\circ$$

$$= V_L I_L \cdot 0$$

$$W_2 = 0$$

Therefore, when the power factor is 0.5, one of the wattmeter reads zero and the other reads total power.

(d) when P.F = 0, $\phi = 90^\circ$

$$W_1 = V_L I_L \cos(30 - \phi)$$

$$= V_L I_L \cos(30 - 90^\circ)$$

$$= V_L I_L \cos(-60)$$

$$= V_L I_L \cdot \cos 60^\circ$$

$$= V_L \cdot I_L \cdot \frac{1}{2}$$

$$W_1 = \frac{V_L \cdot I_L}{2}$$

$$W_2 = V_L I_L \cos(30 + \phi)$$

$$= V_L I_L \cos(30 + 90)$$

$$= V_L I_L \cos 120^\circ$$

$$= V_L I_L \cos 120^\circ$$

$$= V_L \cdot I_L \cdot \left(-\frac{1}{2}\right)$$

$$W_2 = -\frac{V_L I_L}{2}$$

$$W_2 = -W_1$$

Therefore, with zero power factor, the readings of the two wattmeters are equal but of opposite sign.

CHAPTER-4 ENERGY METERS AND MEASUREMENT OF ENERGY

4.1 INTRODUCTION

Energy is the total power delivered or consumed over a time interval.

$$\text{Energy} = \text{Power} \times \text{Time}$$

Electrical energy developed as work or dissipated as heat over an interval of time 't' may be expressed as

$$W = \int_0^t v i dt$$

4.2 SINGLE PHASE INDUCTION TYPE ENERGY METERS-CONSTRUCTION,WORKING PRINCIPLE, AND THEIR COMPENSATION & ADJUSTMENTS

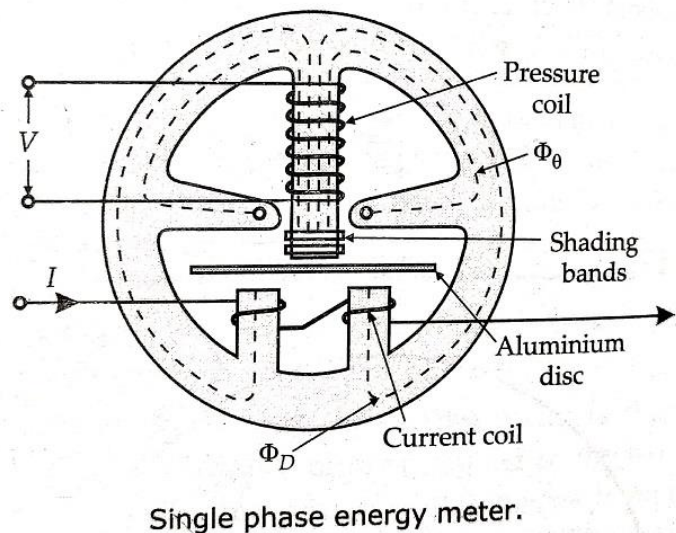

Construction:-

There are four main parts of the operating mechanism

- Driving system
- Moving system
- Braking system
- Registering system

(a) Driving system

- The Driving system consists of two electromagnets one is “shunt” magnet and another is “series” magnet.
- The pressure coil is wound on the central limb of the shunt magnet and this coil is connected across the supply mains. It has large number of turns with thin wire.
- The current coil is wound on the series magnet and this coil is connected in series with load. It has less number of turns of with thick wire.

- Copper shading bands are provided on the central limb and the position of these bands is adjustable.

(b) Moving System

- It consists of an aluminum disc mounted on a light alloy shaft and placed in between the series and shunt magnets.

(c) Braking System

- A permanent magnet is placed near the edge of the aluminium disc forms the braking system.
- The eddy current induced in the aluminium disc produced a braking torque, which opposes the rotation of aluminium disc.

(d) Registering (counting) Mechanism

- A train of reduction gears are used to count the no. of revolution of aluminium disc, which is proportional to the energy consumed in KWH.

Working principle

- When the energy meter is connected in the circuit, the current coil carries the current proportional to the load current and the pressure coil carries the current proportional to the supply voltage.
- The two fluxes produced by the two magnet induced eddy current in the aluminium disc.
- Due to interaction between the two fluxes and two eddy current, a deflecting torque is produced on the aluminium disc.
- The speed of aluminium disc can be controlled by the braking magnet.

TORQUE EQUATION OF INDUCTION TYPE WATTMETER

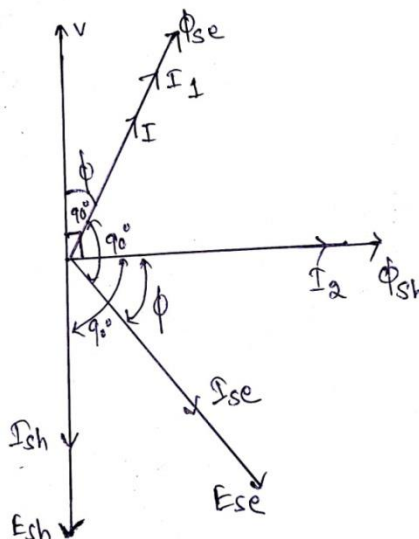

Phasor diagram

Let,

V = supply voltage

I = Load current

I_1 = current carries by series magnet

I_2 = current carries by shunt magnet

- The current I_1 flow through the series magnet proportional to the load current and lag behind the voltage by angle ϕ .
- The current I_2 flow through the shunt magnet proportional to supply voltage (v) and lag behind the voltage by an angle 90° .

$$\text{So } \phi_{sh} \propto v, \phi_{se} \propto I$$

$$T_d \propto \phi_{sh} \cdot \phi_{se} \sin(90 - \phi)$$

$$\Rightarrow T_d \propto v \cdot I \cos \phi$$

$$\Rightarrow \boxed{T_d \propto \text{power}}$$

$$\text{and Braking torque } (T_b) \propto \frac{\phi_b^2 N}{R}$$

where ϕ_b = The flux of braking magnet
 N = The speed of the rotating disc
 R = The resistance of the eddy current path

if $\phi_b, R = \text{constant}$

$$\text{Then } \boxed{T_b \propto N}$$

At final steady state point

$$T_d = T_b$$

$$\Rightarrow \boxed{N \propto \text{power}}$$

COMPENSATION OF ERROR

(a) Light load or friction compensation:-

- Frictional forces at the rotor bearings and in the register mechanism give rise to an unwanted braking torque on the disc.
- This error can be compensated by placing the copper shading bands in the shunt magnet.

(b) Compensation of Creeping:-

- In some meters, a slow but a continuous rotation of aluminium disc is obtained at no load, when the potential coil is only excited. This mechanism is known as creeping.
- Such creeping is prevented by cutting two holes in the disc on opposite side of the spindle.

(c) Temperature of Creeping:-

- Due to temperature the energy metre run faster and register gives wrong value but temperature error is usually small.

(d) Over load Compensation:-

- Overload compensation can be done by providing a permanent or braking magnet on the aluminium disc.
- By adjusting the position of this braking magnet the speed of the aluminium can be control.

(e) Voltage Compensation:-

- The error due to voltage variation can be compensated by increasing the reluctance of the side limbs of shunt magnet.
- The reluctance can be increased by providing holes in the side Limbs of the shunt magnet.

ADJUSTMENT IN METER

- For the energy meter to read accurately, it is need to make some adjustments on the meters.
- The adjustment to be made in sequence are preliminary light rod adjustment, full load Unity factor adjustment, light load adjustment and creep adjustment.

4.3 TESTING OF ENERGY METERS

- Testing of energy meter is done by comparison with the revolution of a sub-standard and the test meter.
- The error of the meter under test is found by counting the number of revolutions and comparing with the number of revolution of the sub standard so percentage of error at any load where anyone is equal to revolution of sub-standard.

$$\text{So error at any load} = \% E = \frac{n_2 k_1 - n_1 k_2}{n_1 k_2} \times 100$$

Where,

n_1 = Revolution of sub-standard energy meter

n_2 = Revolution of test energy meter

K_1 = Constant of standard meter in Revolution per KWH

K_2 = Constant of the test energy meter in Revolution per KWH

CHAPTER-6 MEASUREMENT OF RESISTANCE ,INDUCTANCE & CAPACITANCE

6.1 CLASSIFICATION OF RESISTANCE

The resistances are classified into three categories

(a) Low resistance

➤ The resistance having value of 1Ω or below is classified as Low resistance.

(b) Medium resistance

➤ The resistance from 1Ω to $100\text{ K}\Omega$ is classified as medium resistance.

(c) High resistance

➤ Resistance of the order of $100\text{ K}\Omega$ or $0.1\text{ M}\Omega$ and above is classified as High resistance.

6.1.1 MEASUREMENT OF LOW RESISTANCE BY POTENTIOMETER METHOD

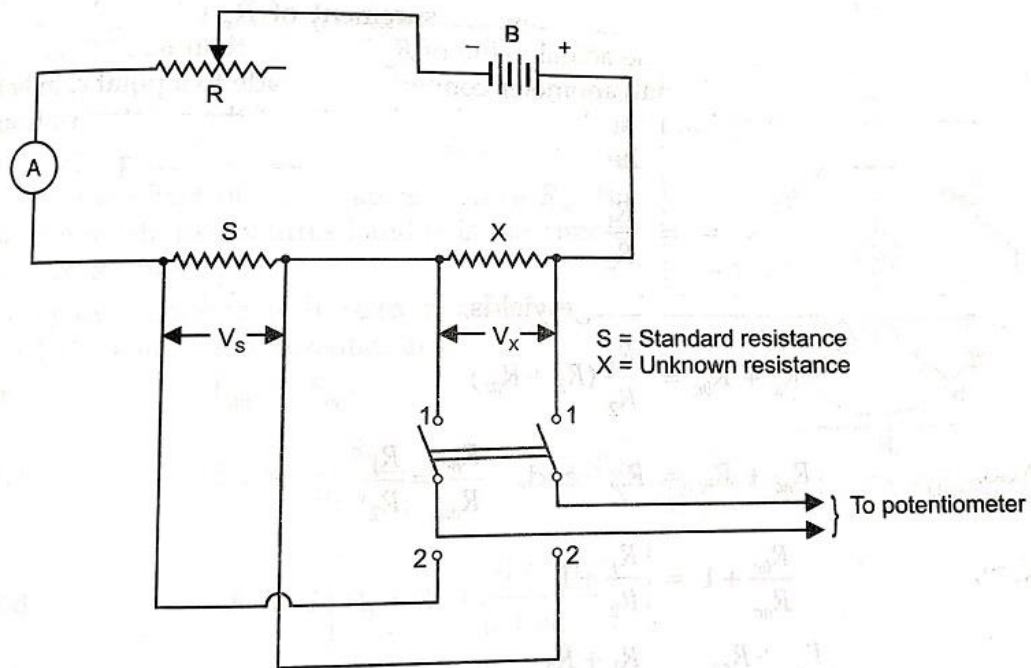

➤ The unknown resistance (X) is connected in series with a standard known resistance (S).

➤ The current through the circuit is controlled by the help of a rheostat (R).

➤ Here a two pole double throw switch is used.

When the switch is in position 1-1, the unknown resistance(X) is connected to the Potentiometer. Let the reading of the Potentiometer is

$$V_x = I \cdot X$$
$$\Rightarrow I = \frac{V_x}{X} \rightarrow \text{eq}^n \text{ (1)}$$

Now the switch is in position 2-2, then the standard resistance (S) is connected to the Potentiometer. Let the reading of the Potentiometer is

$$V_S = I \cdot S$$

$$\Rightarrow \boxed{I = \frac{V_S}{S}} \quad \text{--- eq}^n \text{ (2)}$$

From equation 1 and 2, We get

$$\frac{V_X}{X} = \frac{V_S}{S}$$

$$\Rightarrow \boxed{X = \frac{V_X \cdot S}{V_S}}$$

- Since the value of the standard resistance (S) is accurately known, then the value of unknown resistance (X) can be known accurately.

6.1.2 MEASUREMENT OF MEDIUM RESISTANCE BY WHEAT STONE BRIDGE METHOD

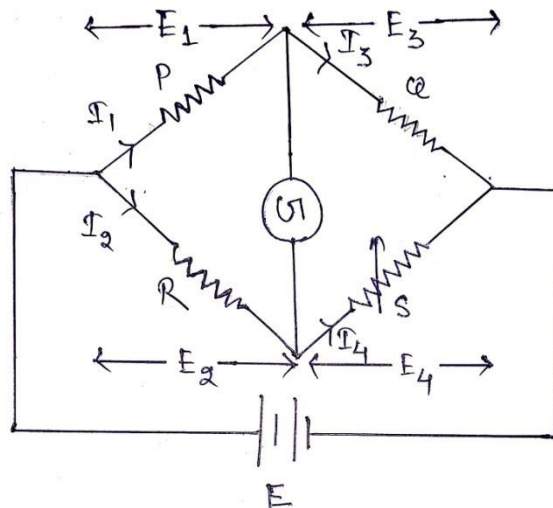

- The Wheat stone Bridge has four resistance arms, consisting of known resistances P, Q, S and unknown resistance 'R' with a source of Battery (E) and a null detector (galvanometer).
- The bridge is said to be balanced only when there is no current through the galvanometer and the potential difference across the Galvanometer is zero.

➤ Hence the bridge is balanced when potential difference between point C and D is equal.

$$V_C = V_D$$

$$\Rightarrow I_1 P = I_2 R \longrightarrow \text{eqn (1)}$$

When the current through the galvanometer is zero, the following condition should be satisfied,

$$I_1 = I_3 = \frac{E}{P+Q}$$

$$\text{and } I_2 = I_4 = \frac{E}{R+S}$$

Substituting the value of I_1 and I_2 in eqn (1), we get

$$\Rightarrow \left(\frac{E}{P+Q} \right) P = \left(\frac{E}{R+S} \right) R$$

$$\Rightarrow \frac{P}{P+Q} = \frac{R}{R+S}$$

$$\Rightarrow P(R+S) = R(P+Q)$$

$$\Rightarrow \cancel{PR} + PS = \cancel{PR} + RQ$$

$$\Rightarrow PS = RQ$$

$$\Rightarrow \boxed{R = \frac{P \cdot S}{Q}}$$

6.1.3 MEASUREMENT OF HIGH RESISTANCE BY LOSS OF CHARGE METHOD

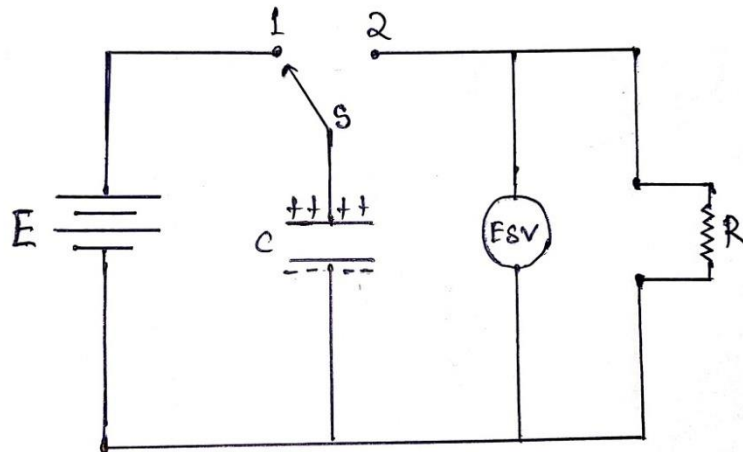

- In this method the resistance 'R' to be measured which is connected in parallel with a capacitor 'C' and an electrostatic voltmeter.
- When the switch (S) is closed to stud-1, then the capacitor is charged to a suitable voltage by means of a battery having voltage 'E'.
- When the switch (S) is closed to stud-2, then the capacitor discharges through resistance R.
- The voltage across the capacitor at any instant of time T-sec after applying the supply voltage 'E' is

$$V = E e^{-T/Rc}$$

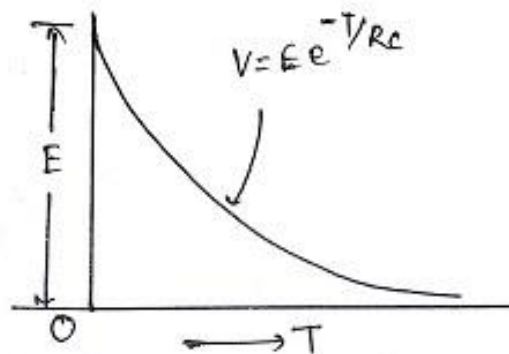

Variation of voltage
with time

Where,

E = voltage across capacitor initially
 v = voltage across capacitor after discharge
for T -sec.

$\tau = RC$ = Time constant

voltage across capacitor at T -sec

$$V = E e^{-T/RC}$$

$$\Rightarrow \frac{V}{E} = e^{-T/RC}$$

$$\Rightarrow e^{-T/RC} = \frac{V}{E}$$

$$\Rightarrow -\frac{T}{RC} = \ln \frac{V}{E}$$

$$\Rightarrow \frac{T}{-\ln \frac{V}{E}} = RC$$

$$\Rightarrow R = \frac{T}{-C \ln \frac{V}{E}}$$

$$\Rightarrow R = \frac{T}{C \ln \left(\frac{E}{V} \right)}$$

$$\Rightarrow R = \frac{T}{C \times 2.303 \log_{10} \left(\frac{E}{V} \right)}$$

$$\Rightarrow R = \frac{0.4843T}{C \log_{10} \left(\frac{E}{V} \right)}$$

From the above equation if the value of E, V, C, T are known then the value of R can be calculated

6.2 CONSTRUCTION, PRINCIPLE OF OPERATIONS OF MEGGER & EARTH TESTER FOR INSULATION RESISTANCE AND EARTH RESISTANCE MEASUREMENT RESPECTIVELY

❖ CONSTRUCTION & PRINCIPLE OF OPERATION OF MEGGER

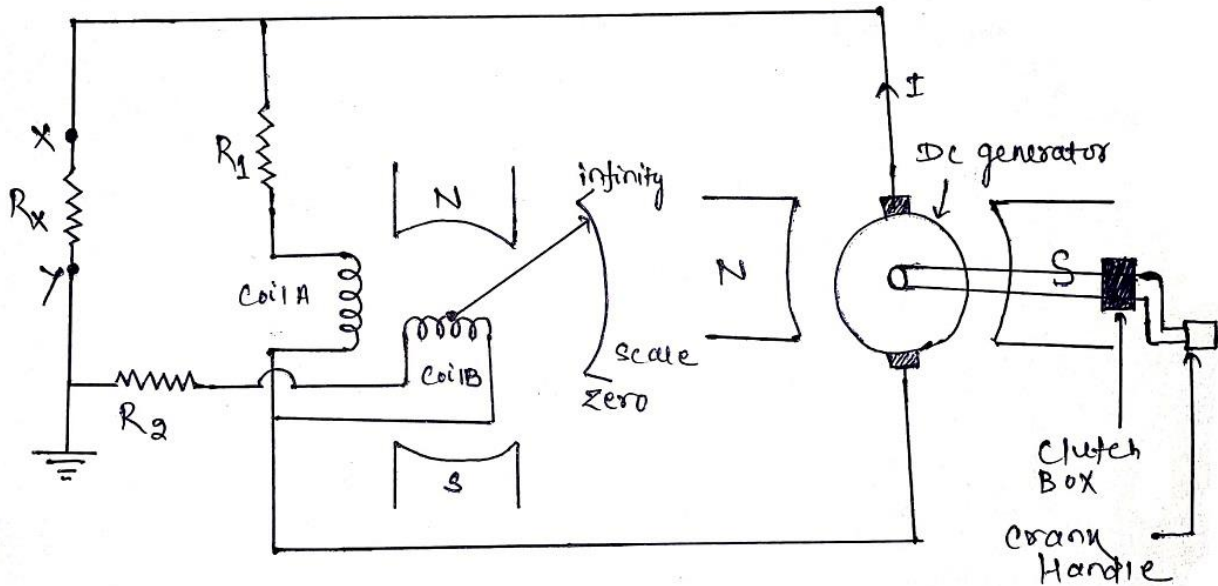

Construction

- Megger is an instrument which is used to measure the insulation resistance and it is also known as Meg-ohm meter.
- It consists of an e.m.f source (DC generator), Pressure coil (coil B), current coil (coil A), Clutch box, Crank handle.
- These two coils are perpendicular to each other and placed in the field of a permanent magnet.
- The voltage for testing is produced by the hand-driven crank which is connected with the generator.
- The unknown resistance ' R_x ' is connected in between the two testing terminals X and Y.
- R_1 and R_2 are current-limiting resistances used for protection of current and pressure coil.

Working principle

- When voltage is produced by the DC generator, then current flows through two coils and two fluxes ϕ_A and ϕ_B are produced.
- These two fluxes produce two torques (T_{d1} & T_{d2}) which act in opposite directions.
- Where these two torques are exactly equal and opposite, the pointer will give the corresponding insulation resistance value.
- The pointer on the scale initially indicates an infinity value. Whenever it experiences a torque, the pointer moves from the infinity position to the zero position on the resistance scale.

Application

- Megger is used to measure the insulation resistance of cables,

- Megger is used to measure the insulation resistance of motor, generator & transformer winding.

❖ MEASUREMENT OF EARTH RESISTANCE

There are two methods used for measurement of earth resistance

- Fall of potential method
- Earth Tester

(a) MEASUREMENT OF EARTH RESISTANCE BY FALL OF POTENTIAL METHOD

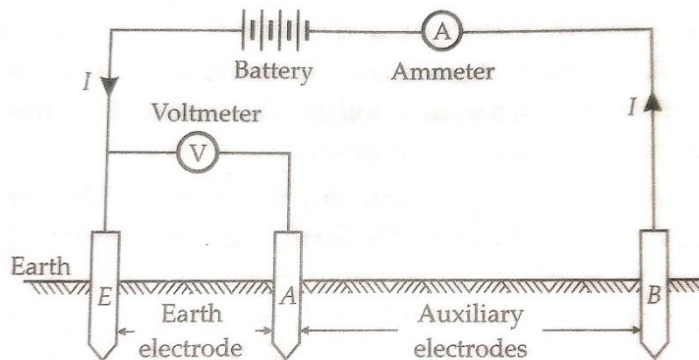

Measurement of earth resistance by fall of potential method.

- A current 'I' is passed through the earthing plate 'E' to an auxiliary electrode 'B' in the ground at a considerable distance away from the plate.
- A second electrode 'A' is inserted in earth between plate 'E' and 'B'.
- The potential difference 'V' between 'E' and 'A' is measured for a given current 'I'. Then the resistance of earth is given by $R_E = \frac{V}{I}$
- The value of R_E depends only on the placing of auxiliary electrodes (A).

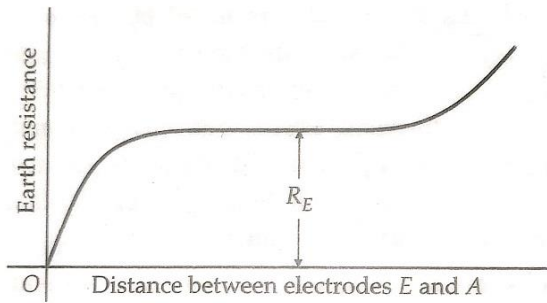
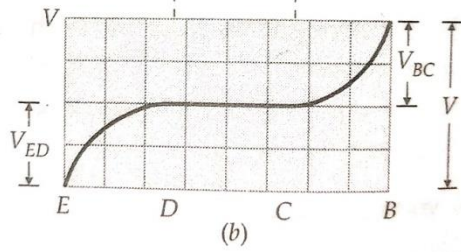
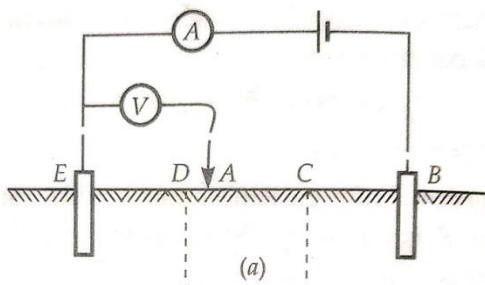

Variation of earth resistance with distance between electrode E and A .

(b) MEASUREMENT OF EARTH RESISTANCE BY EARTH TESTER

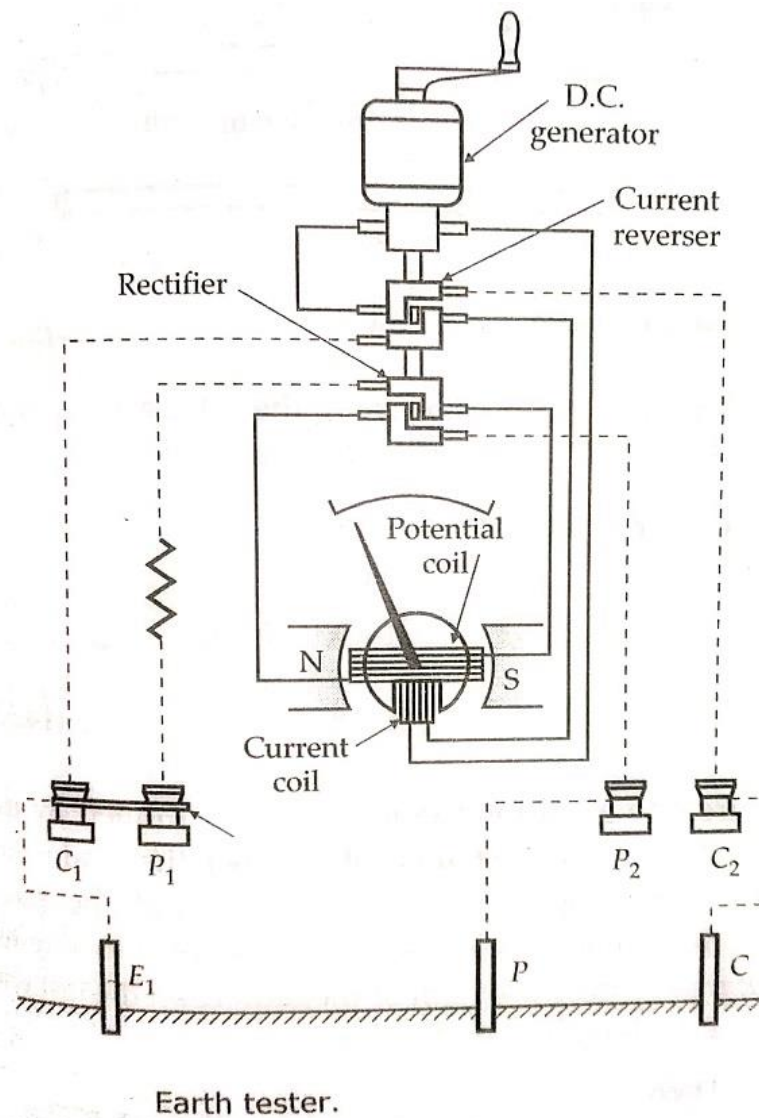

- The earth tester is basically an ohmmeter. Earth tester uses a hand driven DC generator to supply the testing current.
- The ohmmeter consists of two coil current (current coil and pressure coil) mounted at a fixed angle to each other on a common axis.
- It is having four terminal P1, C1, P2, C2 .The terminals P1 and C1 are short circuited to form a common points. Hence it has got three terminals E (common point), P2 and C2.
- When the handle of earth tester is rotated at an uniform speed, it directly indicates the earth resistance on the calibrated scale.
- A current reverse is used to convert DC to AC supply, because only AC supply is required for testing purpose.
- A rectifier is also used on the same shaft to convert AC supply to DC supply because ohm meter is a moving coil instruments.
- The deflection of pointer depends upon the ratio of the voltage across the pressure coil and the current through the current coil.

6.3 CONSTRUCTION AND PRINCIPLES OF MULTIMETER (ANALOG AND DIGITAL)

(a)ANALOG TYPE MULTIMETER

- A multimeter is a Commonly used instrument which is used for multiple measurement with reasonable accuracy such as AC and DC voltage, current and resistance etc.
- Since it is an ammeter, voltmeter and ohm meter combined together so it is called as AVO meter.
- An analog multimeter is basically a PMMC galvanometer i.e the galvanometer is converted into a voltmeter, ammeter and ohm meter with the help of a suitable circuit.

Voltage measurement by using multimeter (D.C)

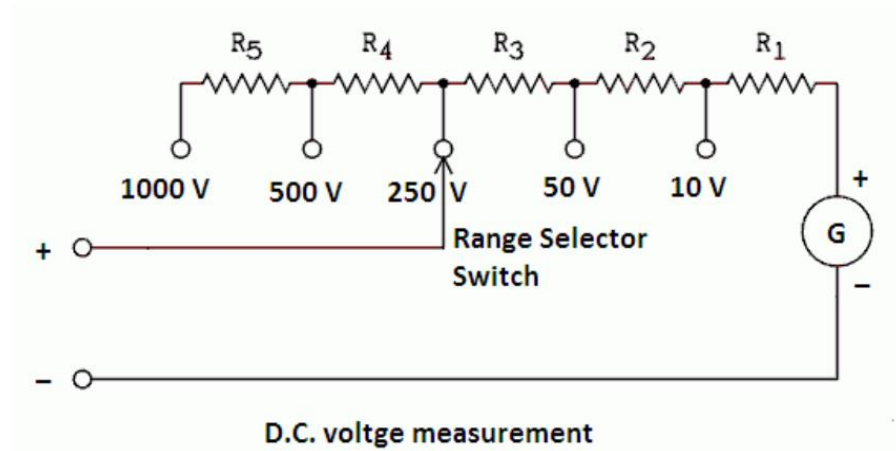

- In the above circuit the high voltage are to be measured by connecting high value of resistance in series with galvanometer.
- If the galvanometer resistance is denoted by G and I_g is the full-scale deflection current and the voltage to be measured is V volts, then the value of series resistance R_s is determined as under,

$$V = I_g R_s + I_g G$$
 or $R_s = (V - I_g G) / I_g$
- This series resistance is also called the multiplier. The voltage range can be increased by increasing the number or value of multipliers.

Voltage measurement by using multimeter (A.C)

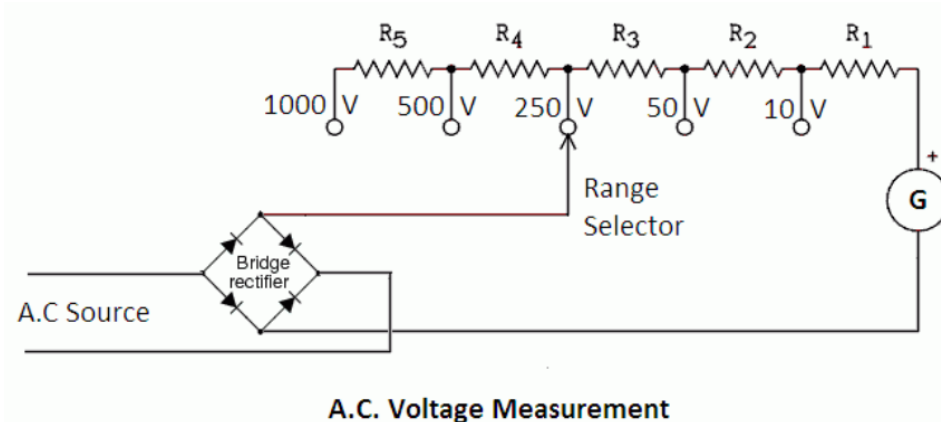

- The multimeter can also use to measure AC voltage. For this purpose, a full-wave rectifier is connected in the multimeter. The rectifier converts AC into DC and the out put is provided to galvanometer

Current measurement by using multimeter (D.C)

- The same galvanometer can be used for measuring current when it is converted into an ammeter by connecting a small resistance R_{sh} in parallel with the meter, as shown in the figure.

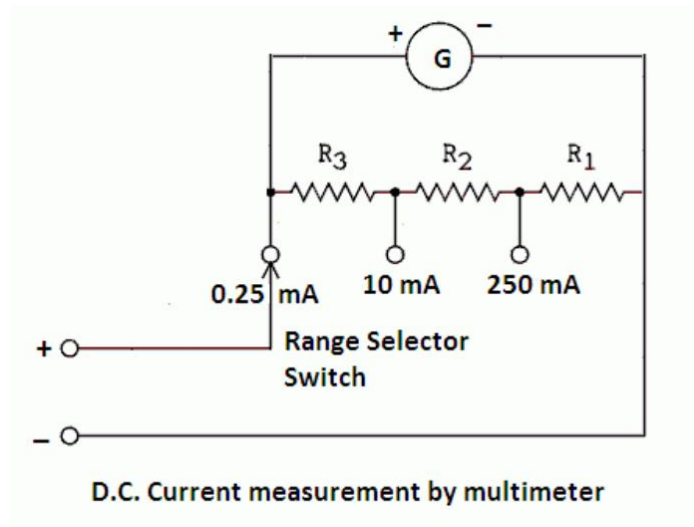

- If G is the internal resistance of meter, I_g its full-scale deflection current and I is the total current to be measured, then the value of shunt resistance R_{sh} required can be found as under:

$$(I - I_g)R_{sh} = I_g G$$
$$\text{or } R_{sh} = I_g G / (I - I_g)$$

Resistance by using multimeter

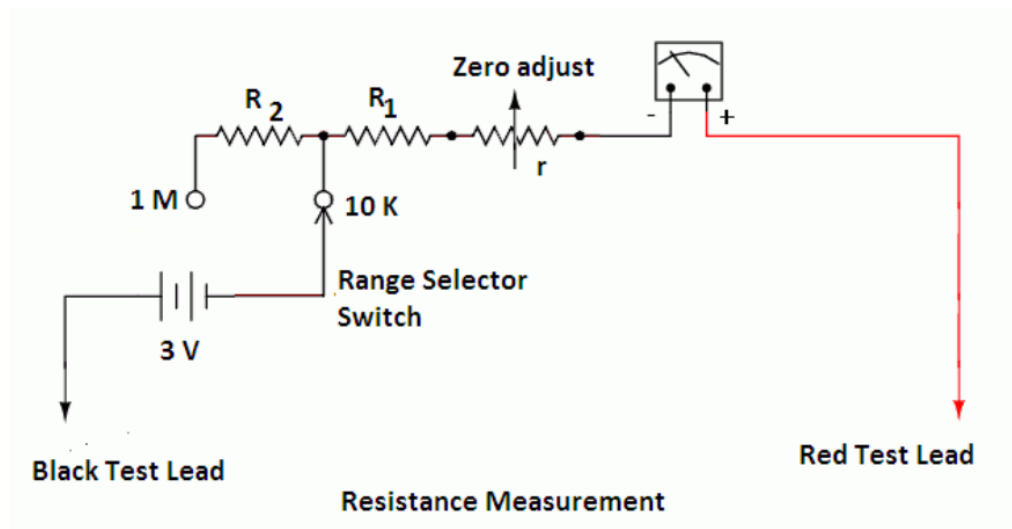

- The same basic instrument can be used as an ohmmeter to measure resistances. In this circuit, an internal battery is connected in series with the meter through an adjustable resistance r and the fixed resistances.

- The resistance to be measured (test resistance) is connected between test leads. The current flowing through the circuit depends upon the resistance of the test piece. The deflection of the needle indicates current, but the scale is calibrated in ohms to give the value of resistance directly.

(b) DIGITAL TYPE MULTIMETER

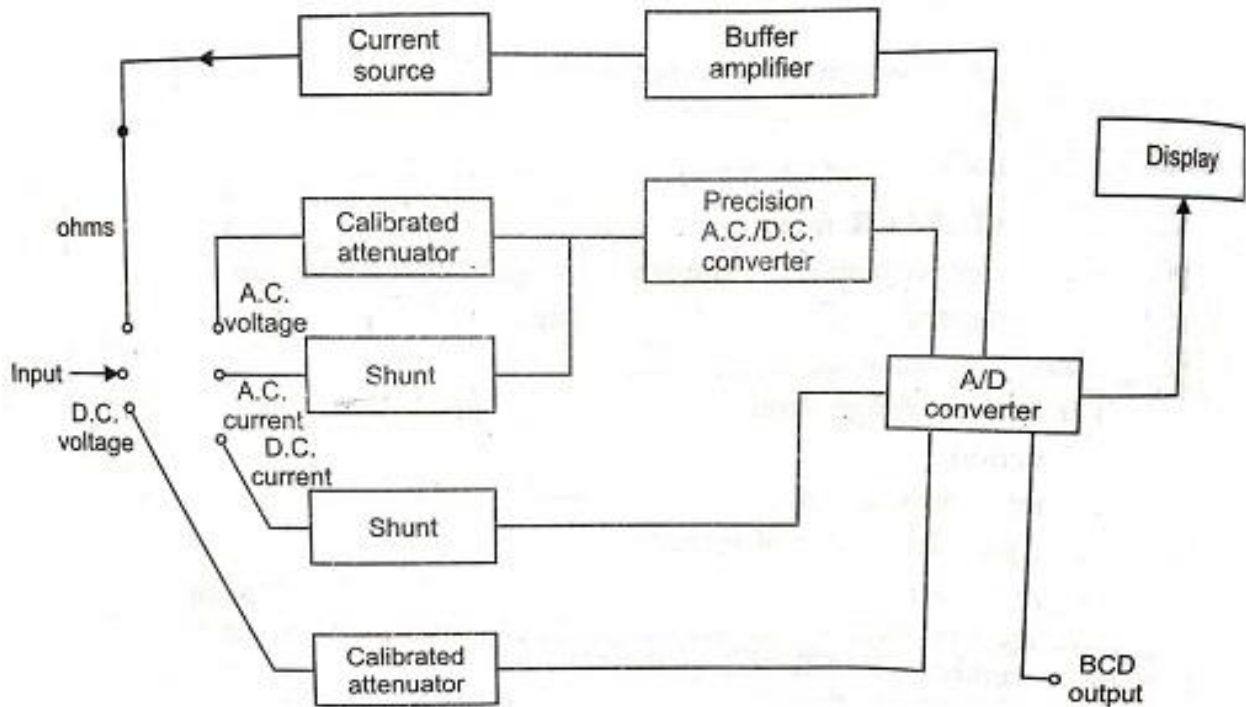

- A digital multimeter offers increased versatility due to additional capability to measure both AC and DC voltage, current and resistance.
- In the AC voltage mode the applied input is fed through a calibrated attenuator to a full wave rectifier circuit which convert it from AC to DC voltage. The resulting DC is fed to the analog to digital converter and subsequent display system.
- For current measurement, the drop across an internal calibrated shunt resistance is measured directly by an analog to digital converter in the DC current mode and after AC to DC conversion in the AC current mode.
- In resistance measurement the digital multimeter operates by measuring the voltage across the externally connected resistance through a constant current source.

6.4 MEASUREMENT OF INDUCTANCE BY MAXWELL'S BRIDGE METHOD

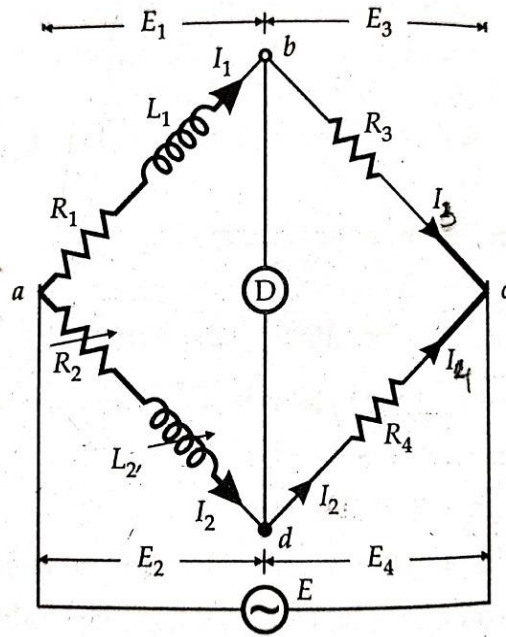

Maxwell's inductance Bridge

In the above figure,

Let

L_1 =Unknown inductance with resistance R_1

L_2 =Variable Inductance

R_2 =Variable resistance

R_3, R_4 =Known resistance

So ,

$$Z_1 = R_1 + j\omega L_1 \quad Z_2 = R_2 + j\omega L_2$$

$$\Rightarrow Z_1 = R_1 + j\omega L_1 \quad \Rightarrow Z_2 = R_2 + j\omega L_2$$

$$Z_3 = R_3 \quad Z_4 = R_4$$

At balanced condition

$$Z_1 Z_4 = Z_2 Z_3$$

$$\Rightarrow (R_1 + j\omega L_1) R_4 = (R_2 + j\omega L_2) R_3$$

$$\Rightarrow R_1 R_4 + j\omega L_1 R_4 = R_2 R_3 + j\omega L_2 R_3$$

By equating the real parts

$$R_1 R_4 = R_2 R_3$$

$$\Rightarrow \boxed{R_1 = \frac{R_2 R_3}{R_4}}$$

By equating the imaginary parts

$$\omega L_1 R_4 = \omega L_2 R_3$$

$$\Rightarrow L_1 R_4 = L_2 R_3$$

$$\Rightarrow \boxed{L_1 = \frac{L_2 R_3}{R_4}}$$

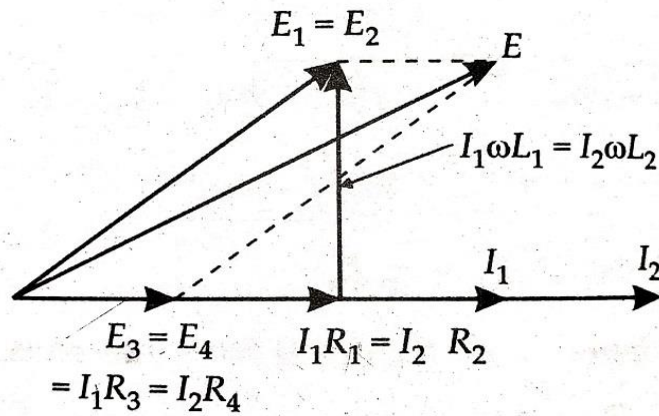

Phasor Diagram

6.5 MEASUREMENT OF CAPACITANCE BY SCHERING BRIDGE METHOD

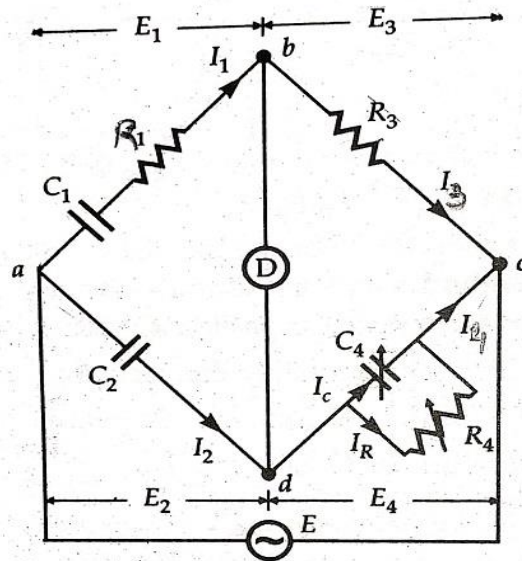

Schering's Bridge

In the above figure,

Let

C_1 =Unknown Capacitance with internal resistance R_1

C_2 =Standard Capacitance

C_4 =Variable Capacitance

R_4 =Variable resistance

R_3 =Known resistance

$$Z_1 = R_1 + \frac{1}{j\omega C_1} \quad Z_2 = \frac{1}{j\omega C_2}$$

$$Z_3 = R_3 \quad Z_4 = R_4 \parallel \frac{1}{j\omega C_4}$$

$$= R_4 \times \frac{1}{j\omega C_4}$$

$$\frac{R_4 \times \frac{1}{j\omega C_4}}{R_4 + \frac{1}{j\omega C_4}}$$

$$= \frac{R_4}{\frac{j\omega C_4 R_4 + 1}{j\omega C_4}}$$

$$\Rightarrow Z_4 = \frac{R_4}{1 + j\omega C_4 R_4}$$

At balanced condition

$$Z_1 Z_4 = Z_2 Z_3$$

$$\Rightarrow \left(R_1 + \frac{1}{j\omega C_1} \right) \left(\frac{R_4}{1 + j\omega C_4 R_4} \right) = R_3 \left(\frac{1}{j\omega C_2} \right)$$

$$\Rightarrow \left(\frac{1 + j\omega C_1 R_1}{j\omega C_1} \right) \left(\frac{R_4}{1 + j\omega C_4 R_4} \right) = \frac{R_3}{j\omega C_2}$$

$$\Rightarrow (1 + j\omega C_1 R_1) R_4 C_2 = R_3 C_1 (1 + j\omega C_4 R_4)$$

$$\Rightarrow R_4 C_2 + j\omega C_1 R_1 R_4 C_2 = R_3 C_1 + j\omega C_4 R_4 R_3 C_1$$

By equating the Real part

$$R_4 C_2 = R_3 C_1$$

$$\Rightarrow \boxed{C_1 = \frac{R_4 C_2}{R_3}}$$

By equating the imaginary part

$$\cancel{C_1 R_1 R_4 C_2} = \cancel{C_4 R_4 R_3 C_1}$$

$$\Rightarrow R_1 C_2 = C_4 R_3$$

$$\Rightarrow \boxed{R_1 = \frac{C_4 R_3}{C_2}}$$

Phasor diagram

